

**piececool**

**DRAGON GATE CARPS  
HP153**

**Assembly Instructions**

© Wist Plastic & Metal Technology Limited. All rights reserved.

# Installation Reminder:



**WARNING** – Please handle metal sheets with care. The parts may have sharp edges that could cut or scratch skin. Keep away from children.

## ● Prepare tools:

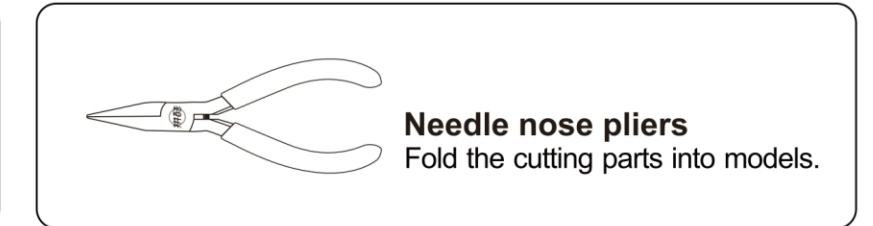
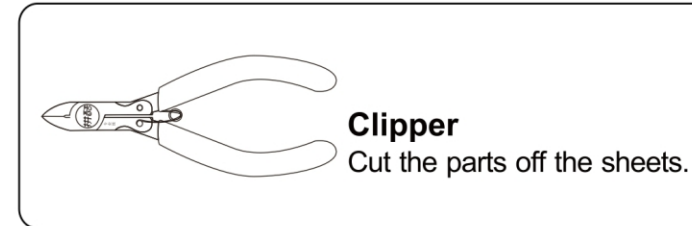

It is recommended to use piececool authentic assembly tools to build or fix the design. It is tailor made for the metal pieces and user friendly.

## ● Installation Method:

### a. Remove the parts



Please use the clipper to cut the nozzle position and remove the parts.

### b. Identify the parts

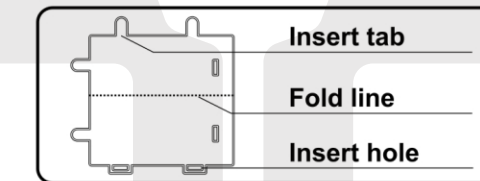

Identify the insert tab, fold line and the insert hole.

### c. Folding the parts

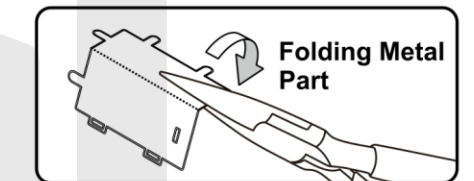

Please use the Needle nose pliers to fold the cutting parts into models.

### d. Retaining the parts

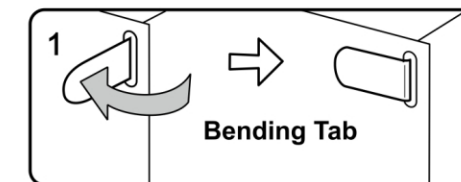

● Insert the hole, bending tab with angle 90°.

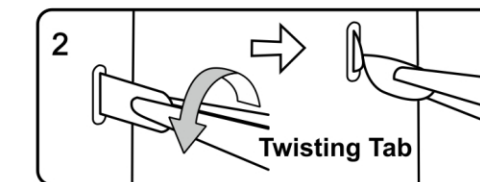

▲ Insert the hole, twisting tab with angle 90°.

## ● Attention:

- Engraved / Color side
- Non-engraved / Silver side
- Attention Point
- Keep the parts symmetrical

When cutting metal parts, please do not cut the “insert tab” as “nozzle position”. Only cut the parts of the current step when cutting the parts. Do not cut all the parts at one time to avoid loss.

When encountering the parts of the folding line, please pay attention to the front and back of the metal sheet and the direction of the folding. According to the direction indicated in the instruction, cut lightly and fold slowly. It is best to fold it once. Do not fold it repeatedly to avoid damage to the parts.

# Assembly Guide:

# piece

**Step  
01**

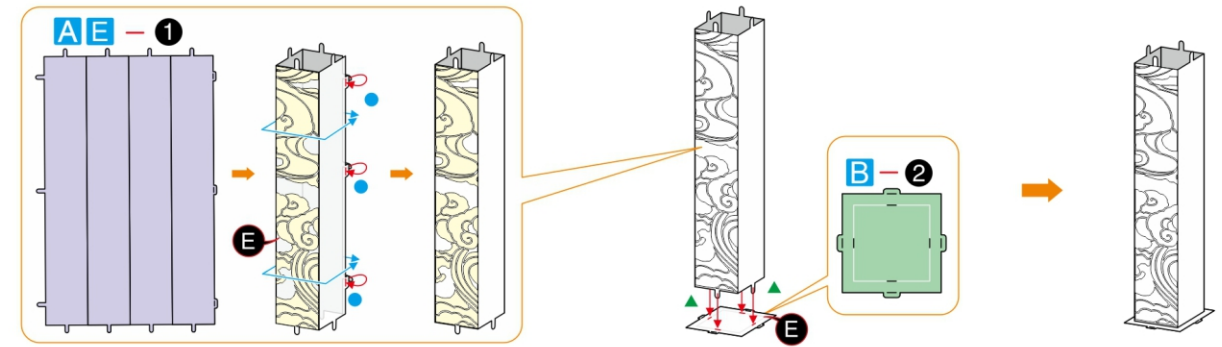

Step.01 ✓

**Step  
02**

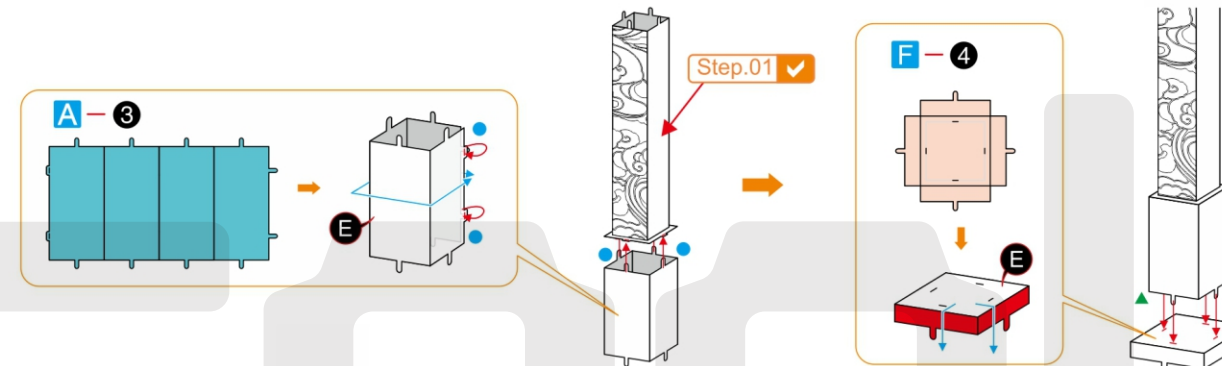

Step.02 ✓

**Step  
03**

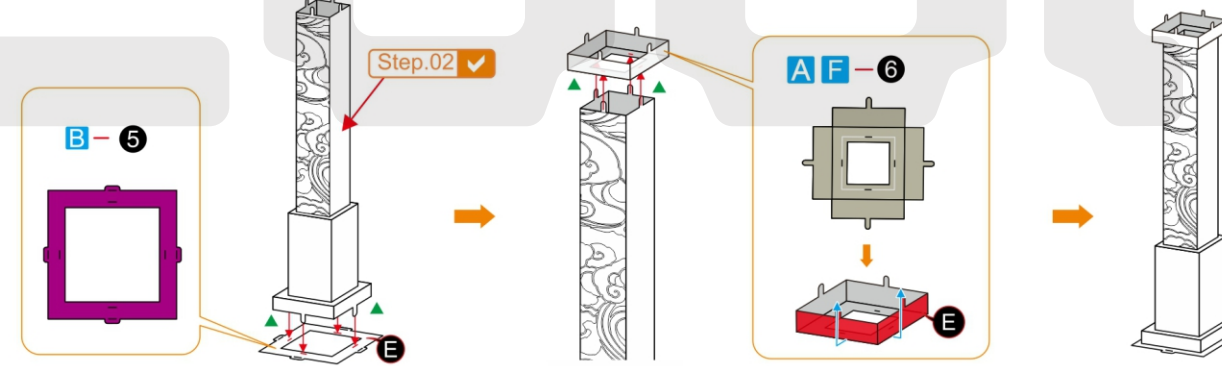

Step.03 ✓

**Step  
04**



Step.04 ✓

**Step 05**

Step.04 ✓

B 8 E

Step.05 ✓

**Step 06**

CD 9 E

Step.06 ✓

**Step 07**

BCDEF 10 E X2

Step.07 ✓

**Step 08**

C 11 E B 12 D 13 E

Step.08 ✓

**Step 09**

BE 14 E

Step.07 ✓

Step.09 ✓

Step.09 ✓

**Step 10**

D 15 E

Step.10 ✓

**Step 11**

CF 16 E CDF 17 E X2

Step.11 ✓

**Step 12**

BDE 18 E X2

Step.11 ✓

Step.12 ✓

**Step 13**

D 19 E

Bend the tab outwards

b X2

Step.10 ✓

Step.12 ✓

Step.13 ✓

**Step 14**

D 19 E

Step.05 ✓

Step.13 ✓

Step.14 ✓

**Step 15**

CF 20 E

Step.15 ✓

**Step 16**

CEF 21 E

Step.16 ✓

**Step 17**

AC 22 E

Step.17 ✓

**Step 18**

DF 23 E CD 24 E C X2

Step.17 ✓

Step.18 ✓

**Step 19**



Step.19 ✓

**Step 20**



Step.20 ✓

**Step 21**

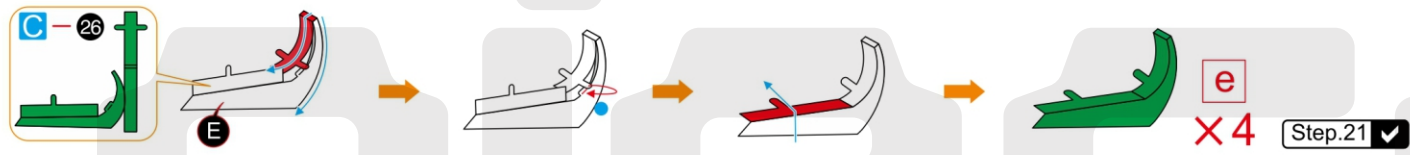

Step.21 ✓

**Step 22**

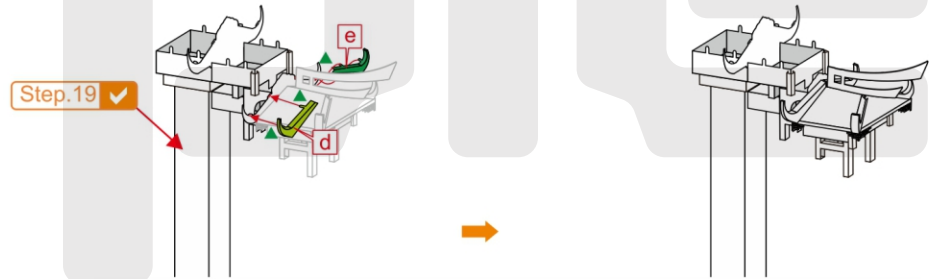

Step.22 ✓

**Step 23**

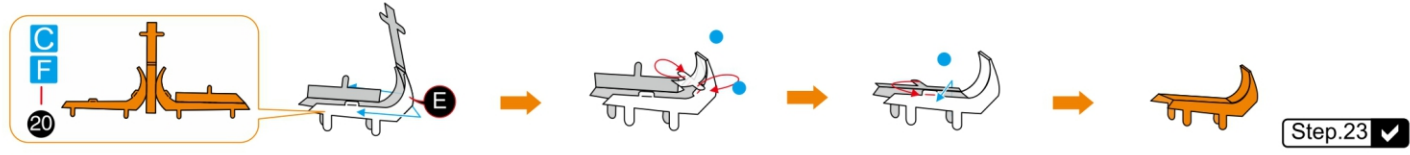

Step.23 ✓

**Step 24**

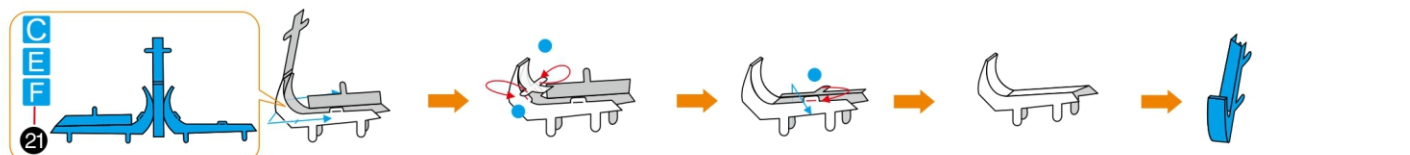

Step.24 ✓

**Step 25**

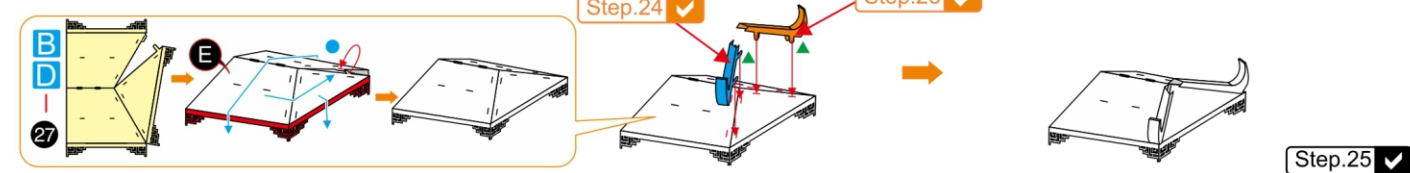

Step.25 ✓

**Step 26**

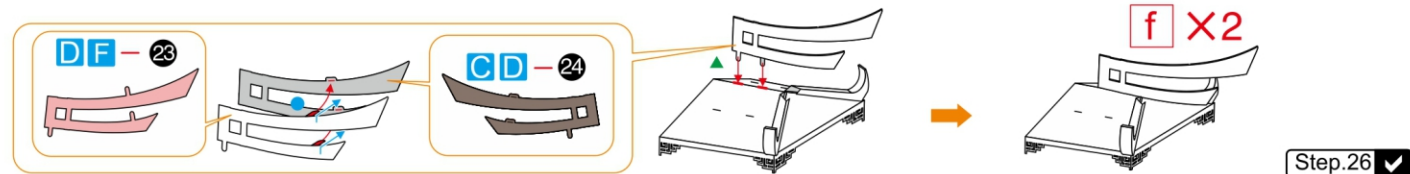

Step.26 ✓

**Step 27**

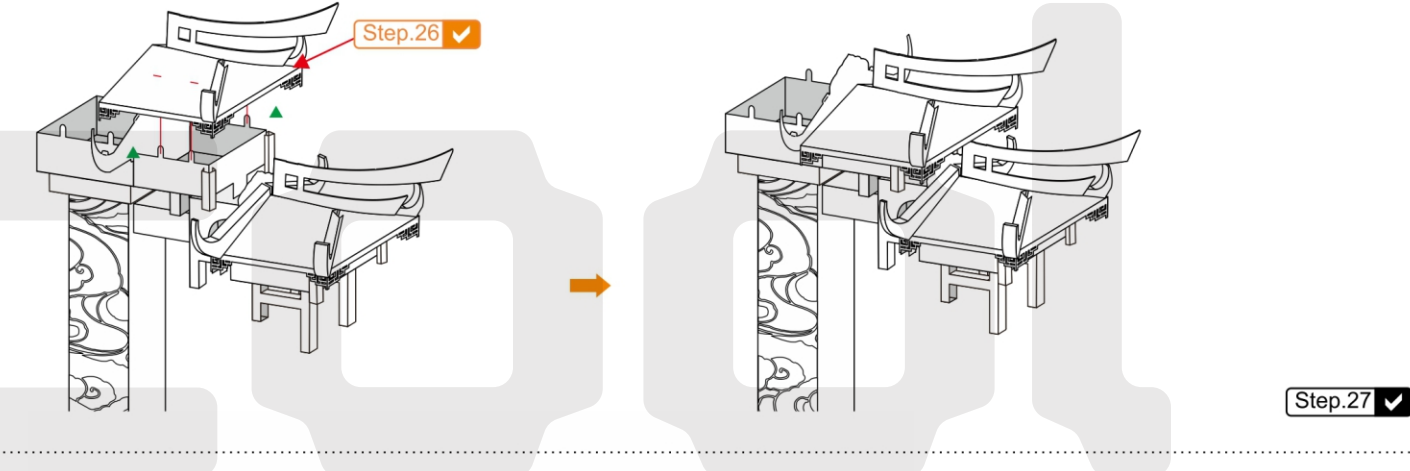

Step.27 ✓

**Step 28**

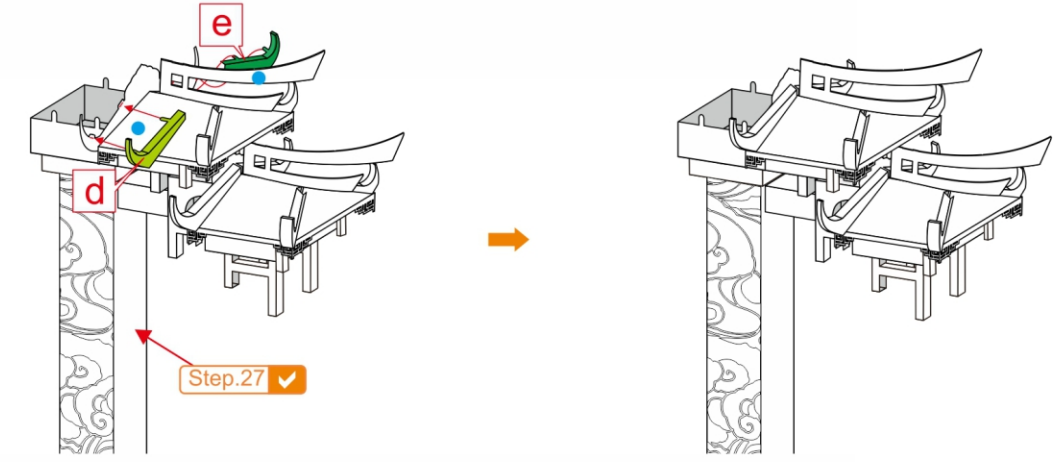

Step.28 ✓

**Step  
29**

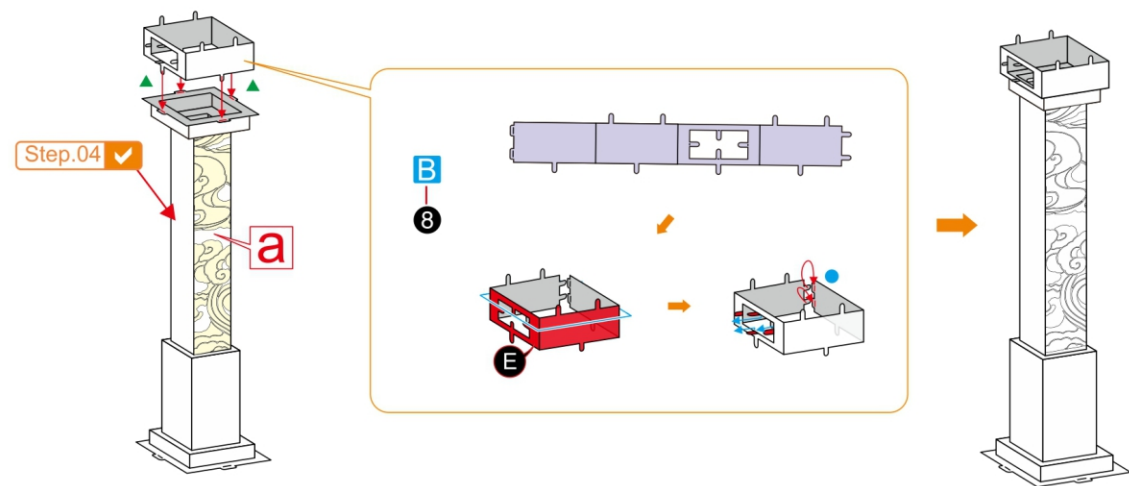

Step.29 ✓

**Step  
30**

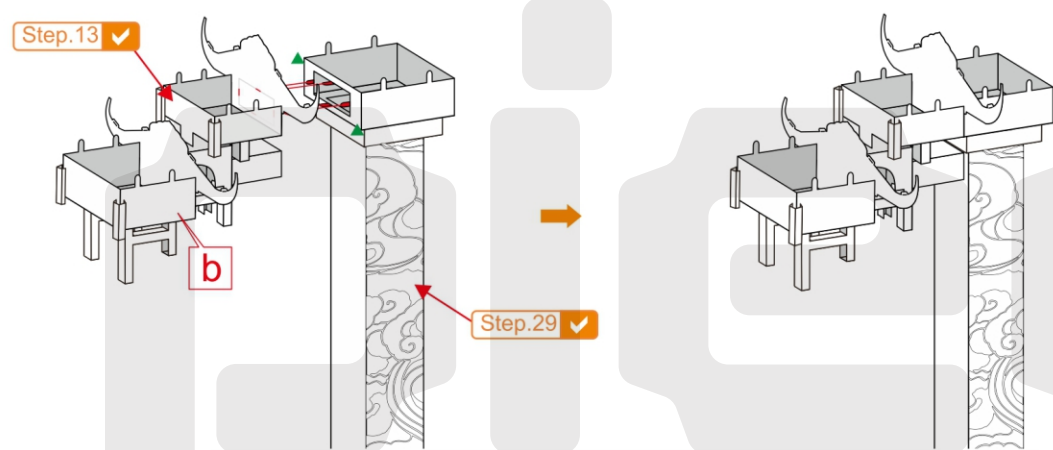

Step.30 ✓

**Step  
31**

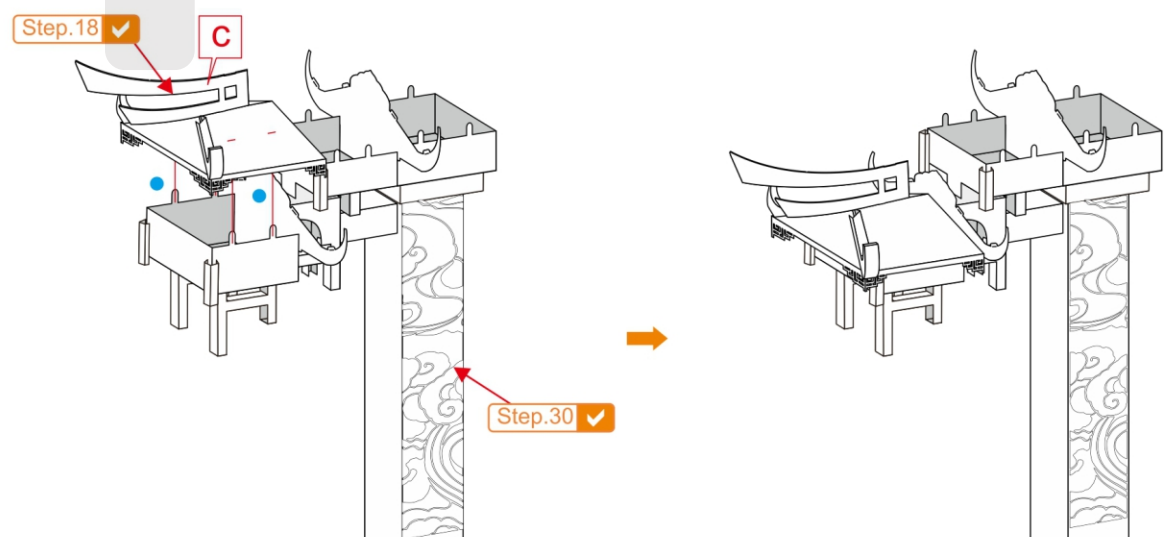

Step.31 ✓

**Step  
32**

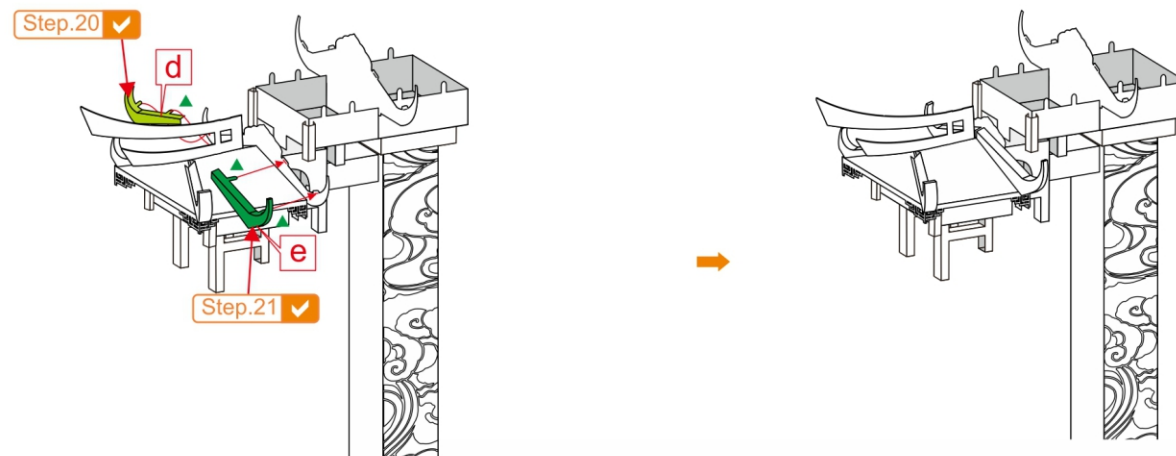

Step.32 ✓

**Step  
33**

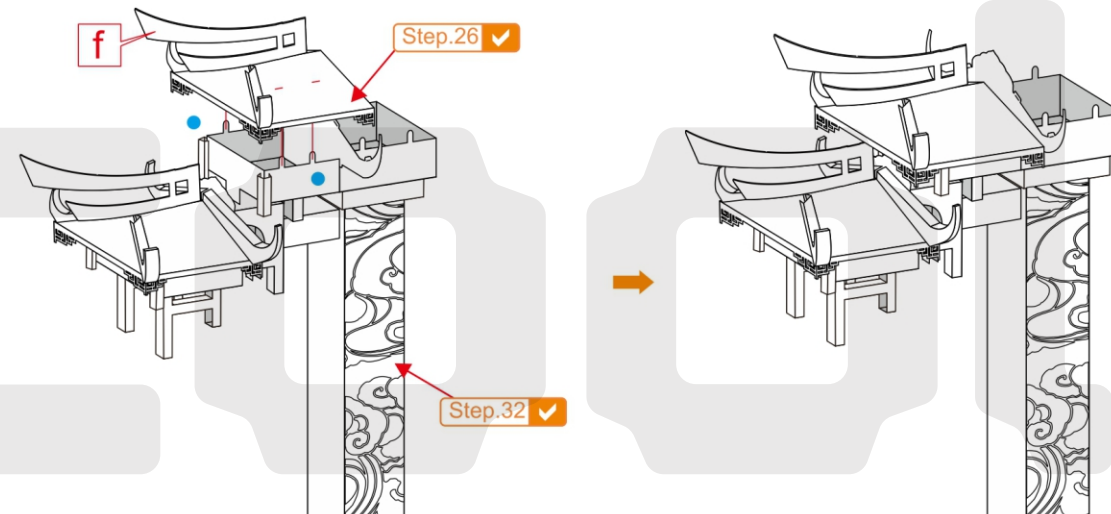

Step.33 ✓

**Step  
34**

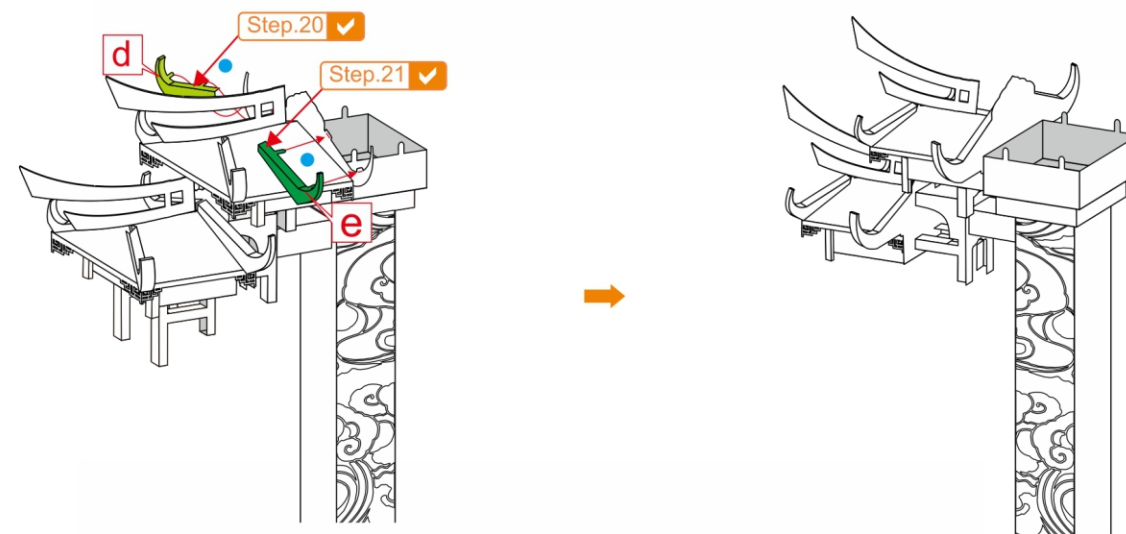

Step.34 ✓

Step 35

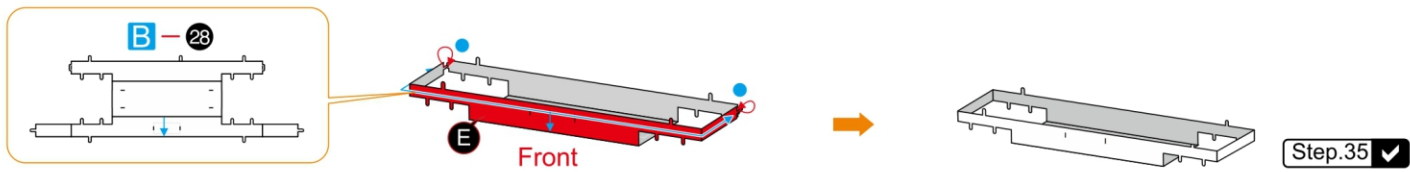

Step 36

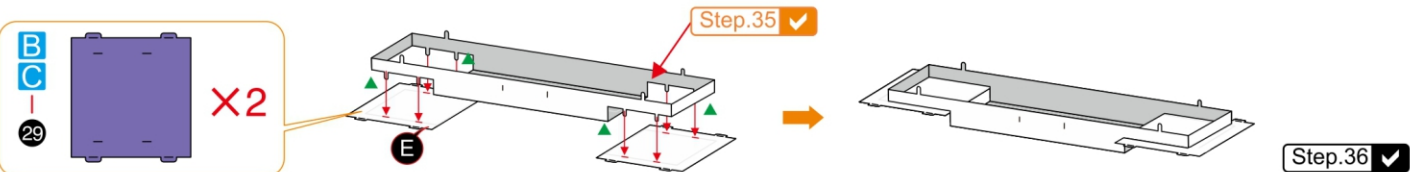

Step 37

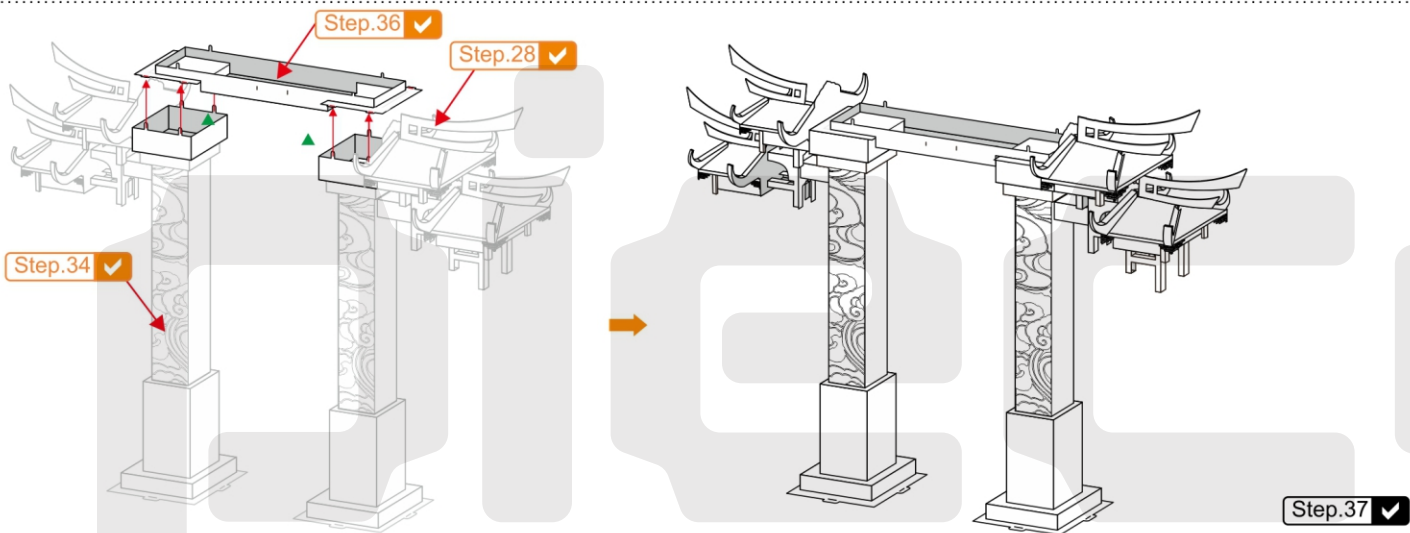

Step 38

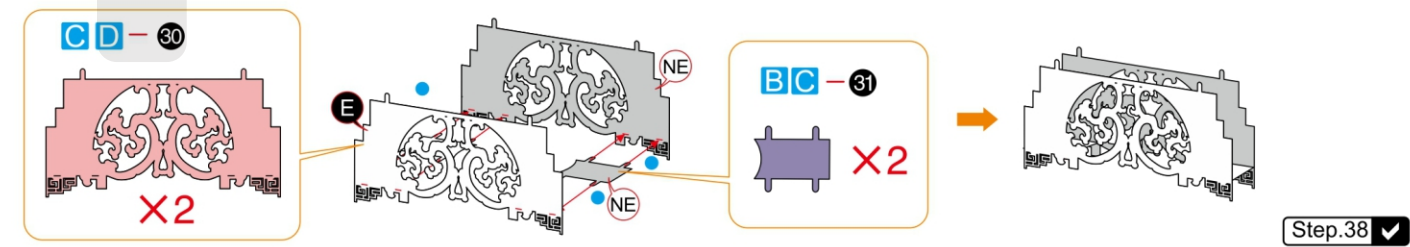

Step 39

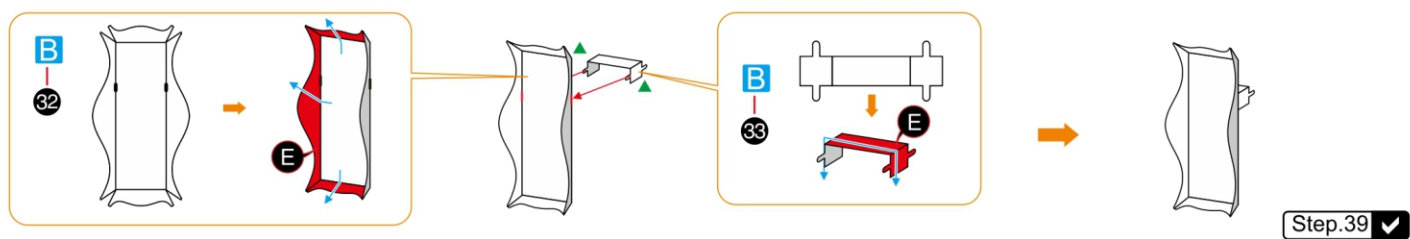

Step 40

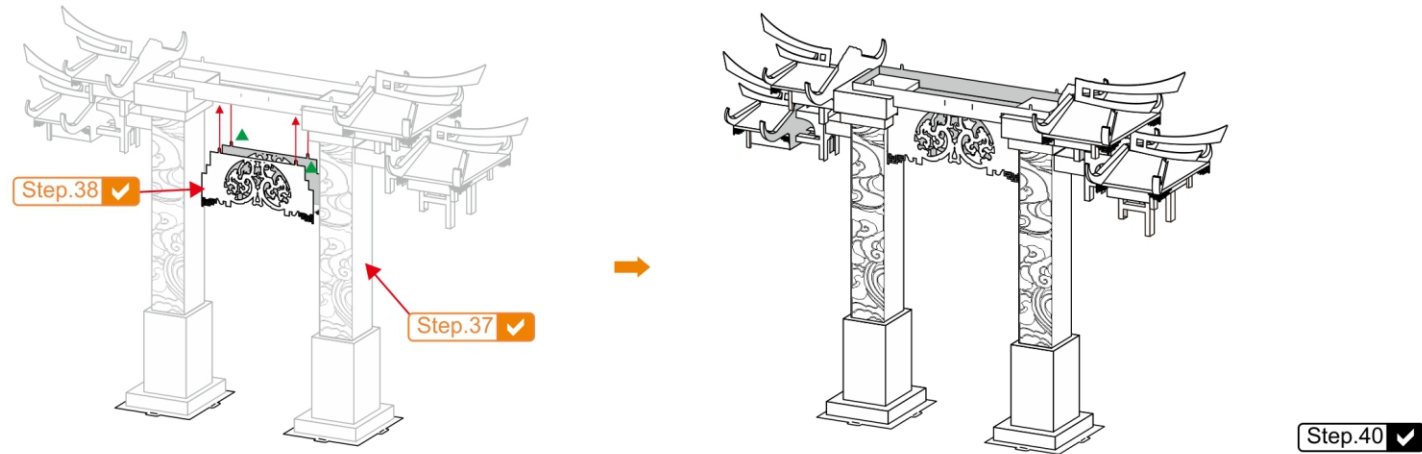

Step 41

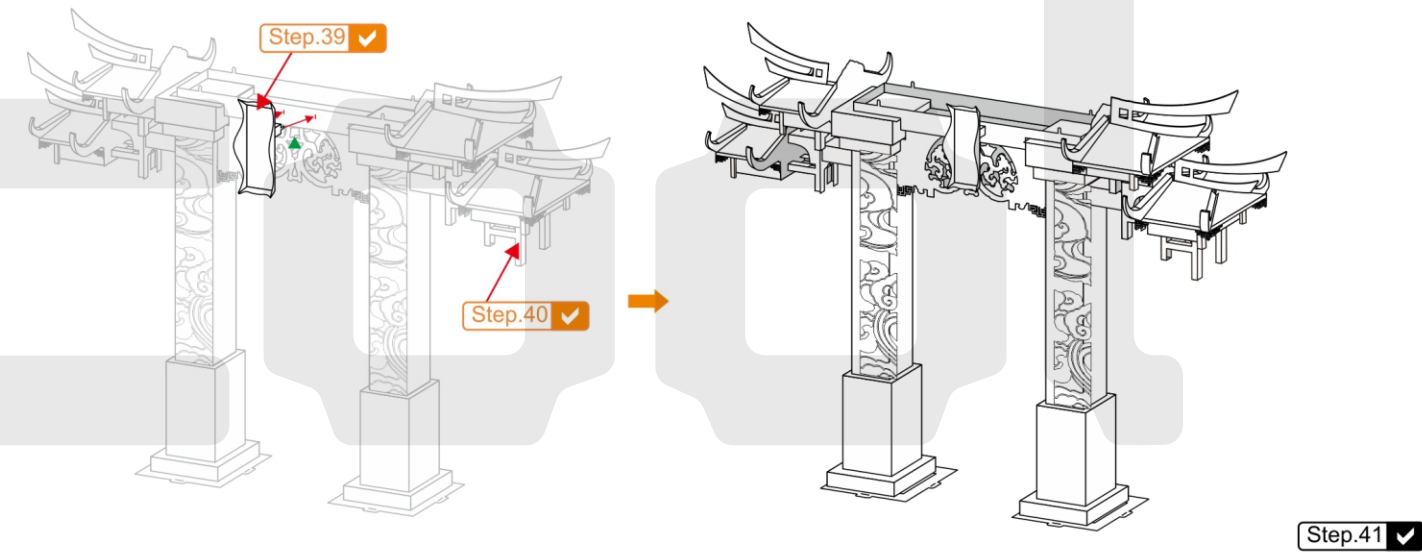

Step 42

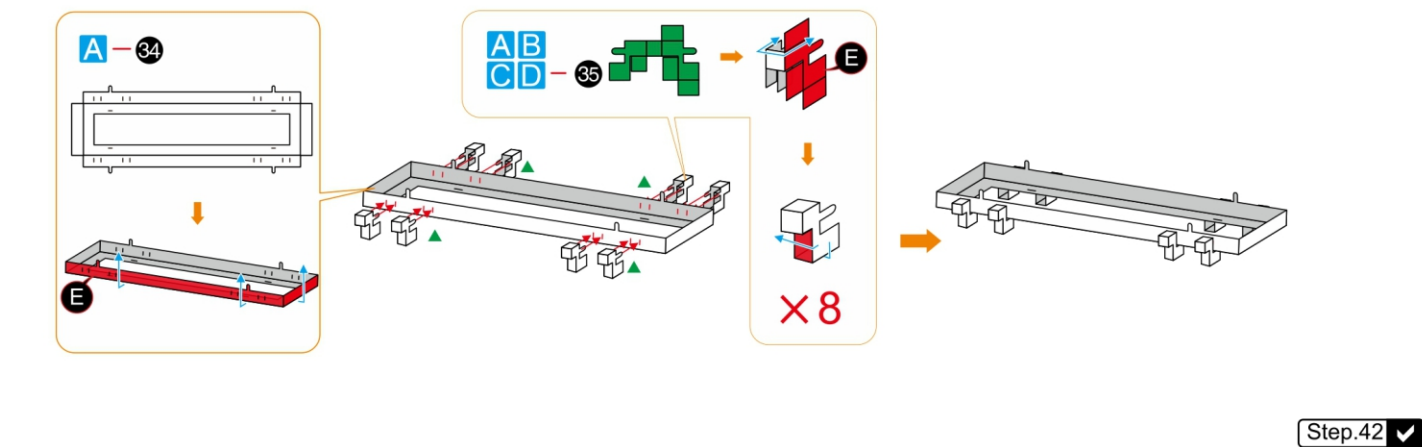

**Step  
43**

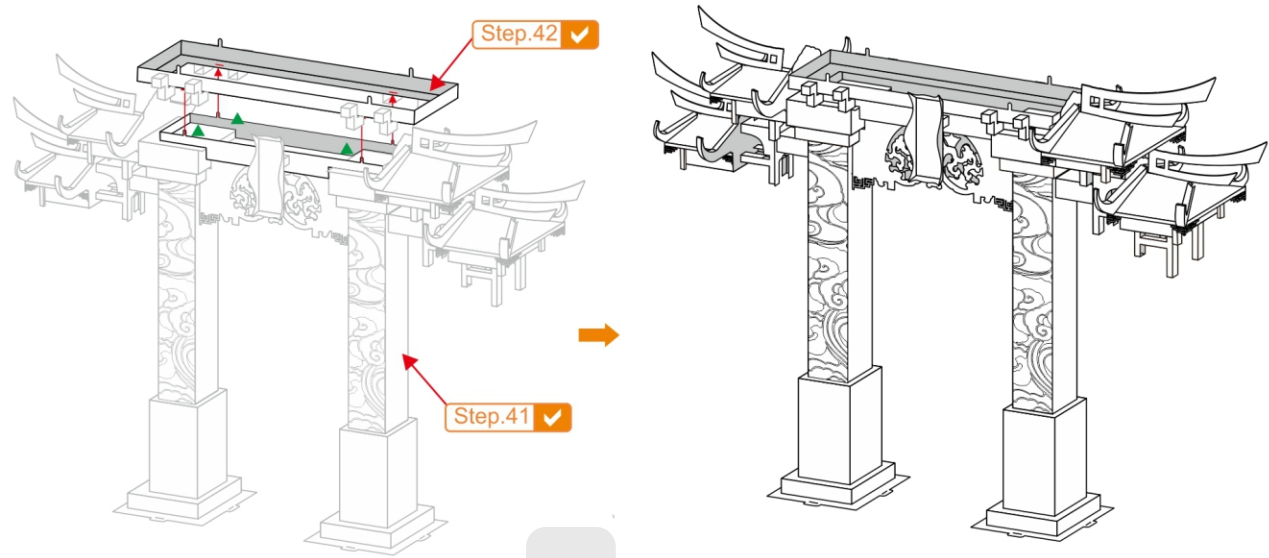

Step.43 ✓

**Step  
44**

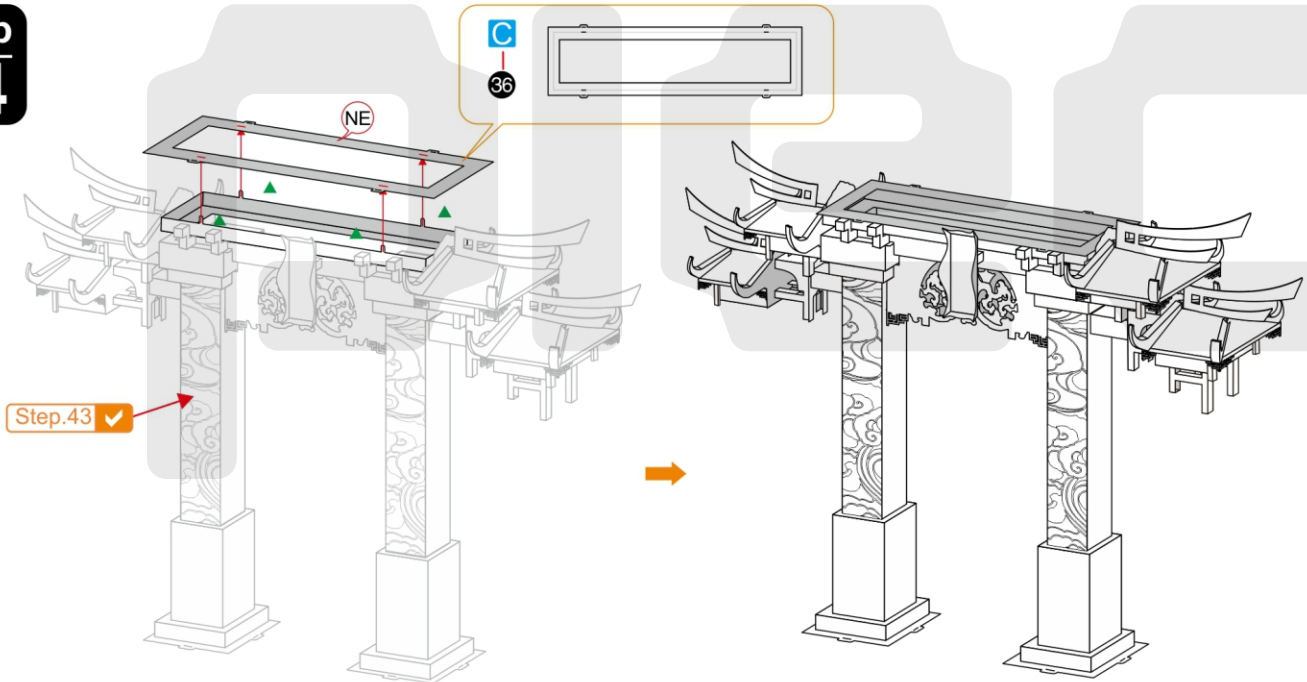

Step.44 ✓

**Step  
45**

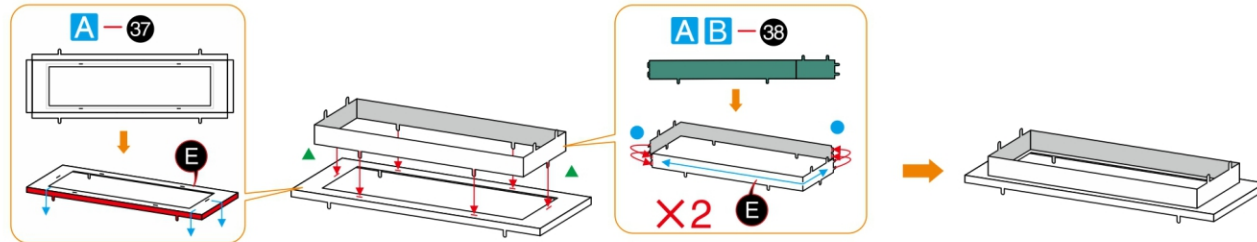

Step.45 ✓

**Step  
46**

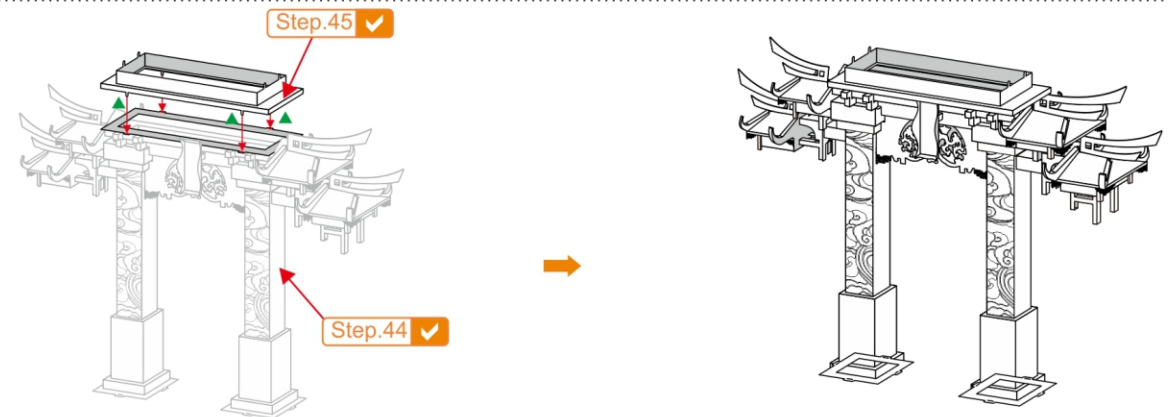

Step.46 ✓

**Step  
47**

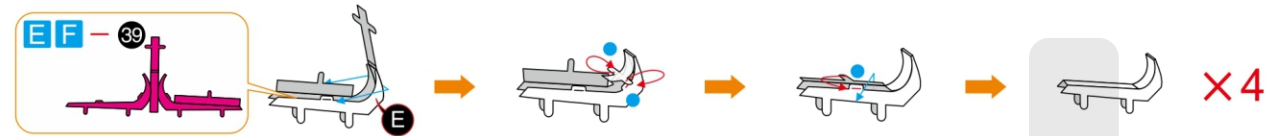

Step.47 ✓

**Step  
48**

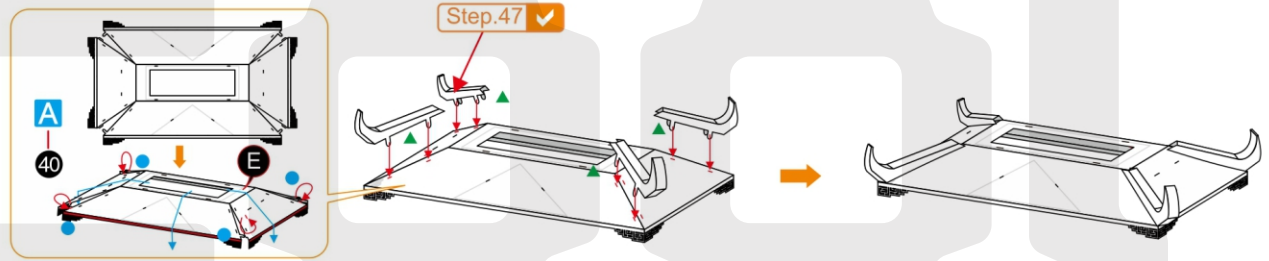

Step.48 ✓

**Step  
49**

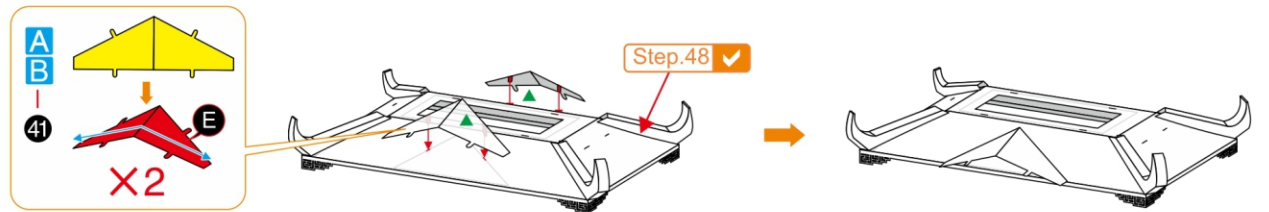

Step.49 ✓

**Step  
50**

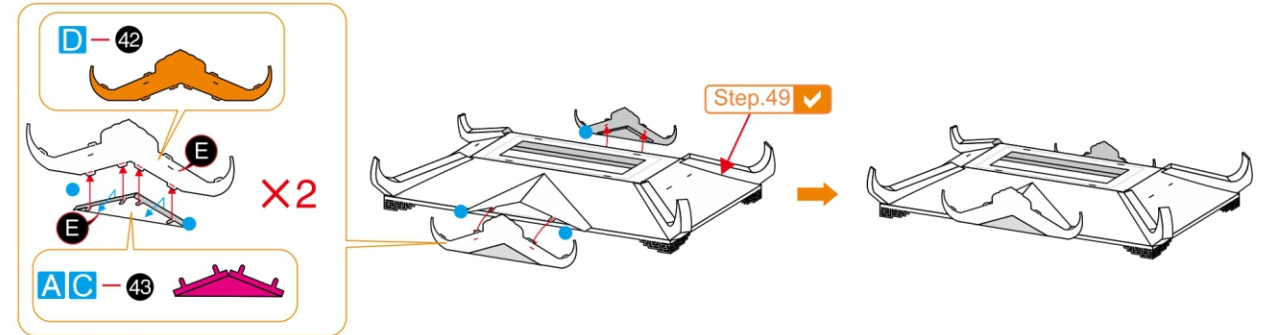

Step.50 ✓



Step 51

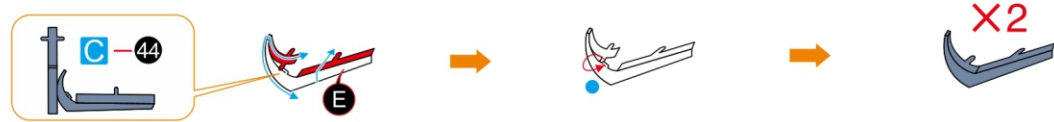

Step.51 ✓

Step 52

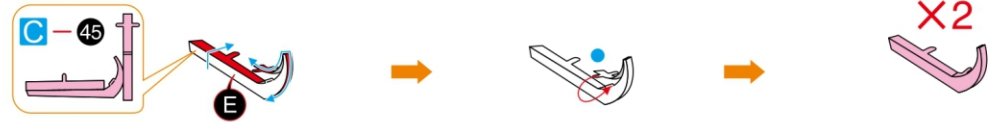

Step.52 ✓

Step 53



Step.53 ✓

Step 54

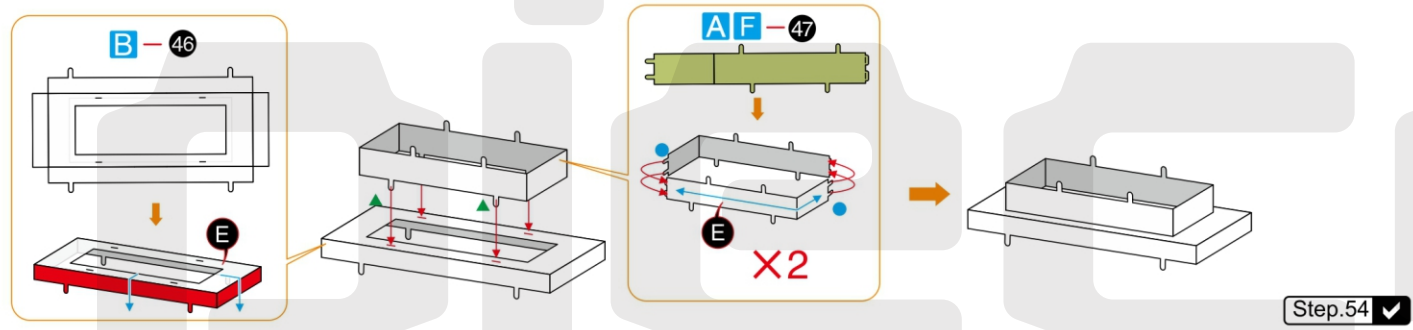

Step.54 ✓

Step 55



Step.55 ✓

Step 56

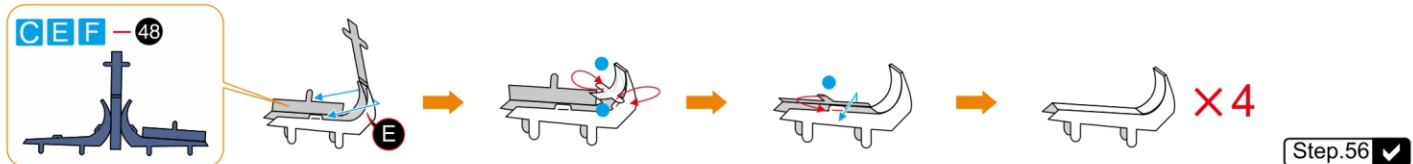

Step.56 ✓

Step 57

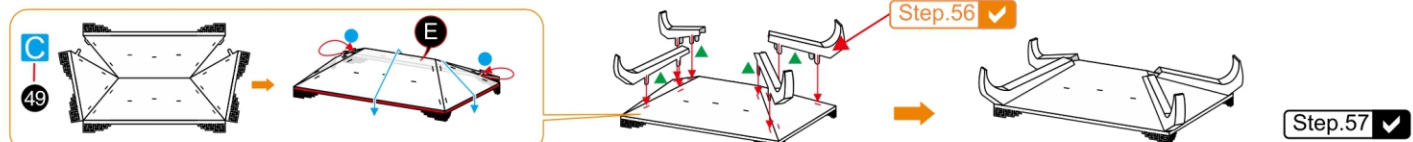

Step.57 ✓

Step 58

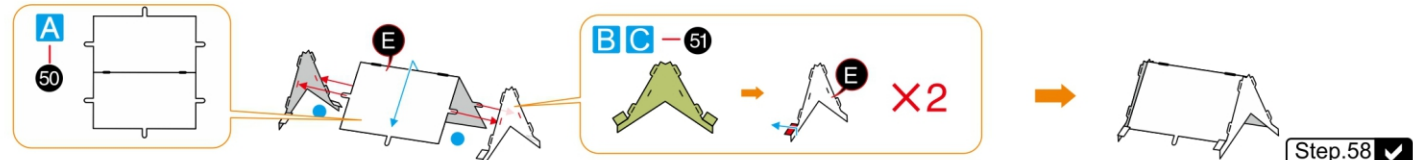

Step.58 ✓

Step 59

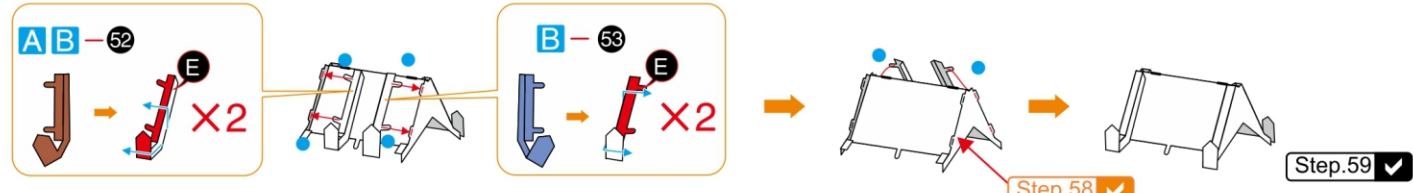

Step.59 ✓

Step 60

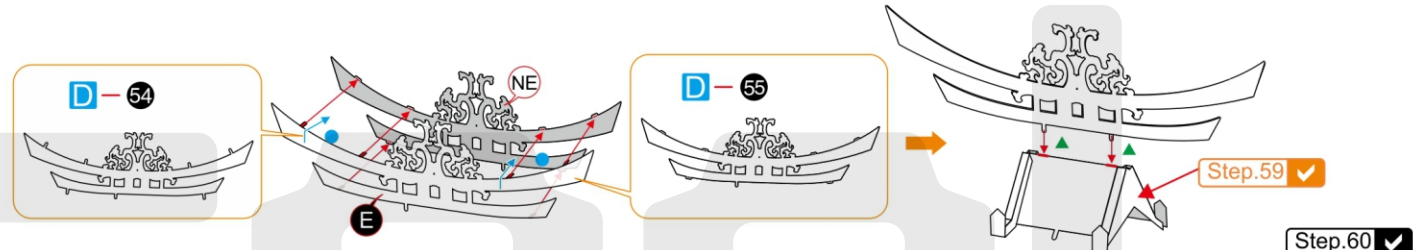

Step.60 ✓

Step 61



Step.61 ✓

Step 62

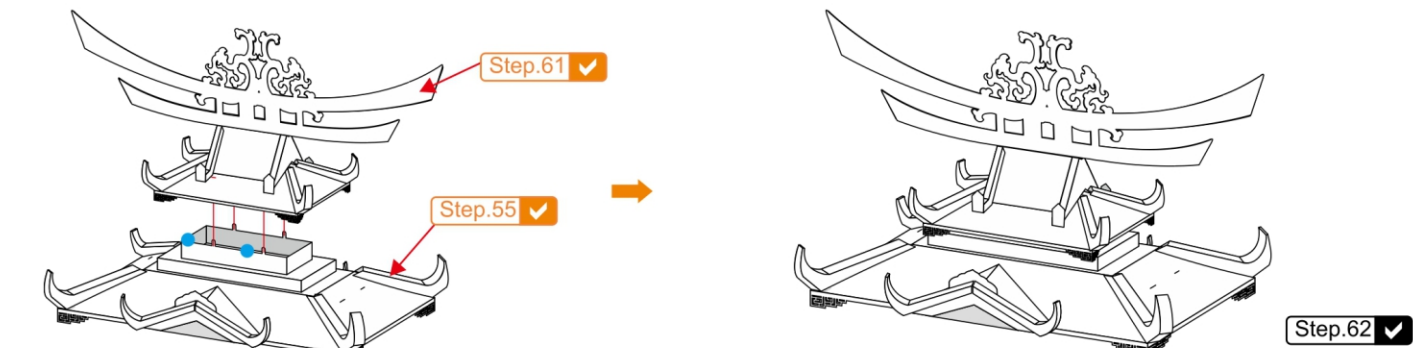

Step.62 ✓

**Step 63**

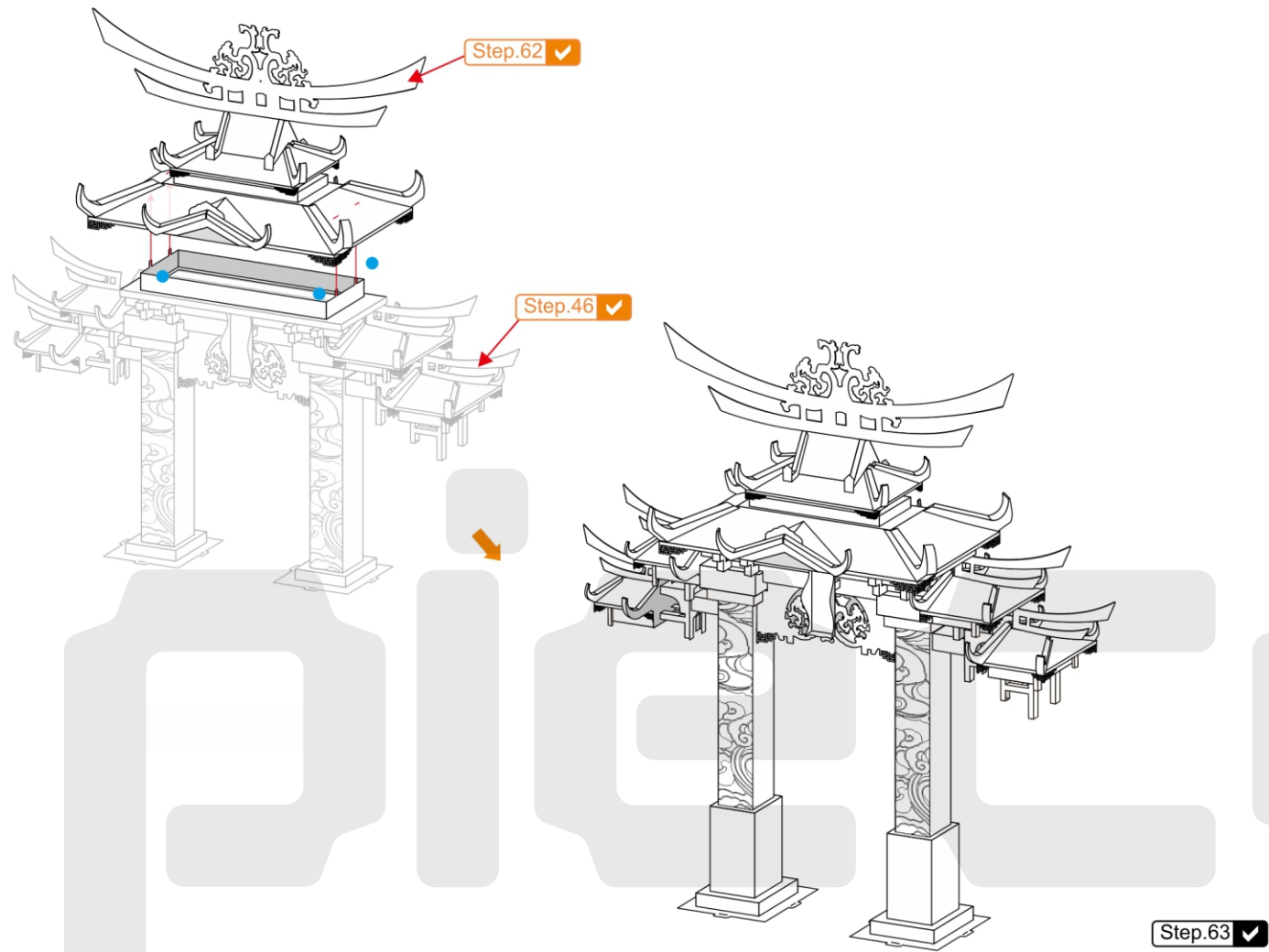

Step.63 ✓

**Step 64**

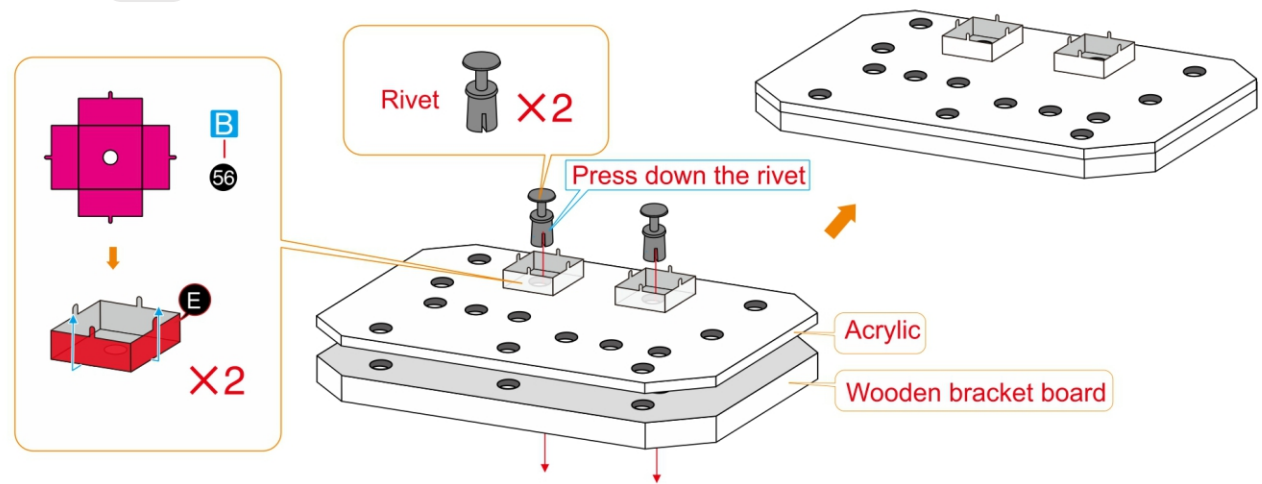

Step.64 ✓

**Step 65**

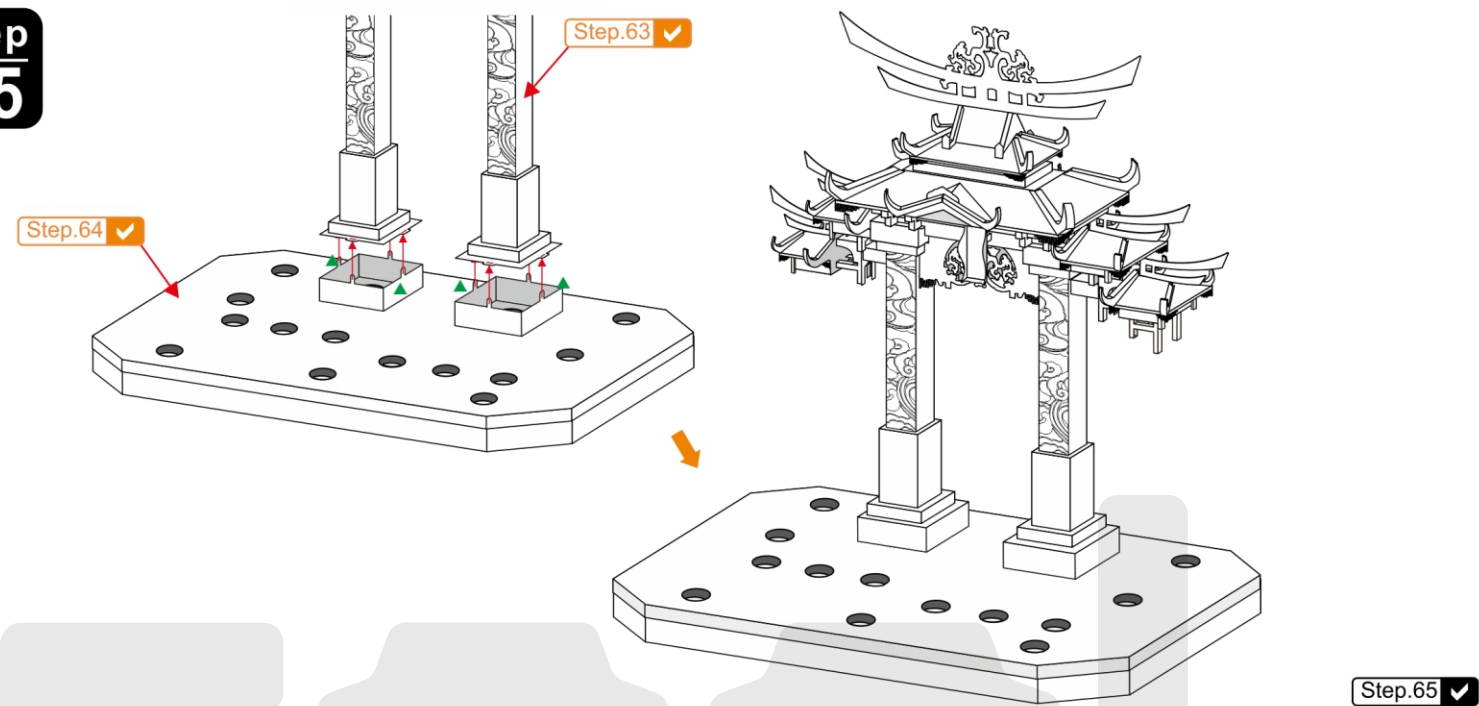

Step.65 ✓

**Step 66**

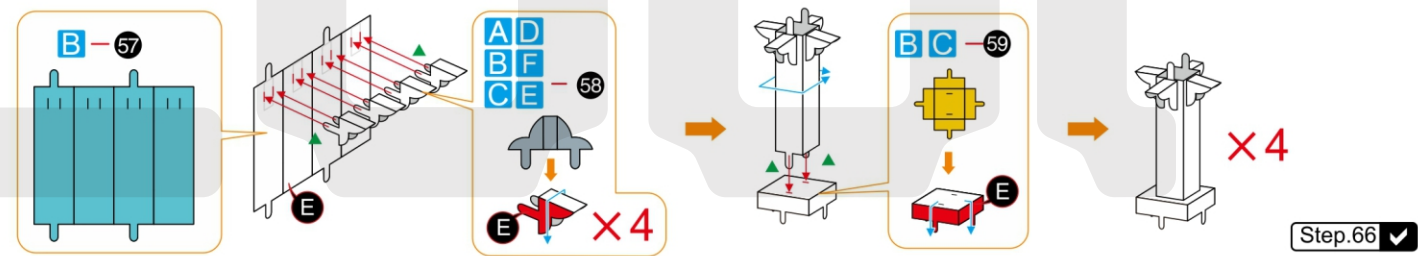

Step.66 ✓

**Step 67**

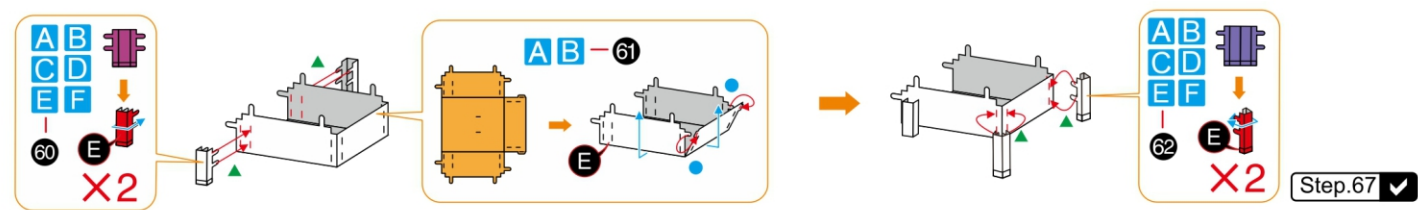

Step.67 ✓

**Step 68**

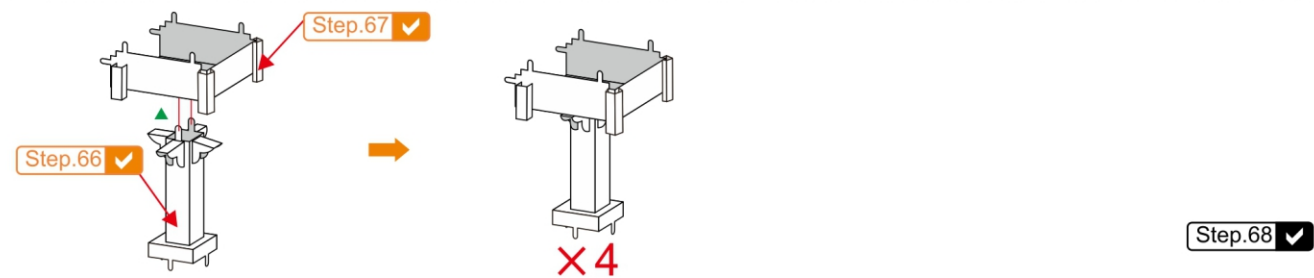

Step.68 ✓

Step  
69

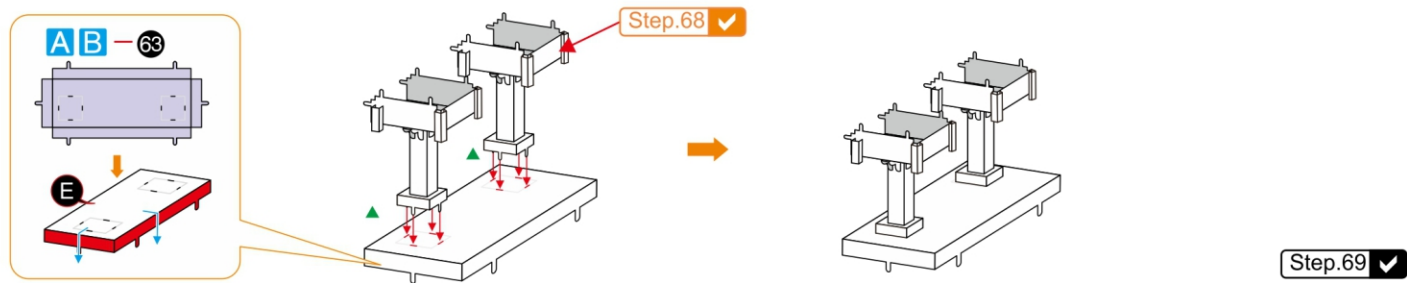

Step  
70

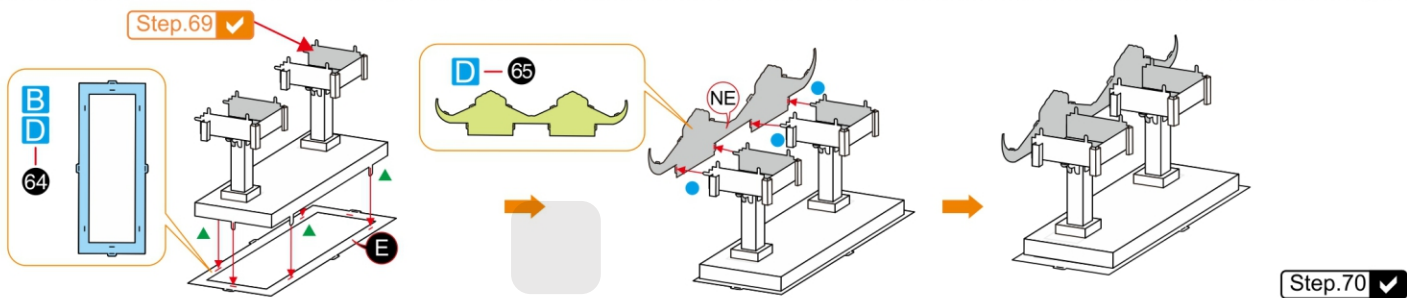

Step  
71

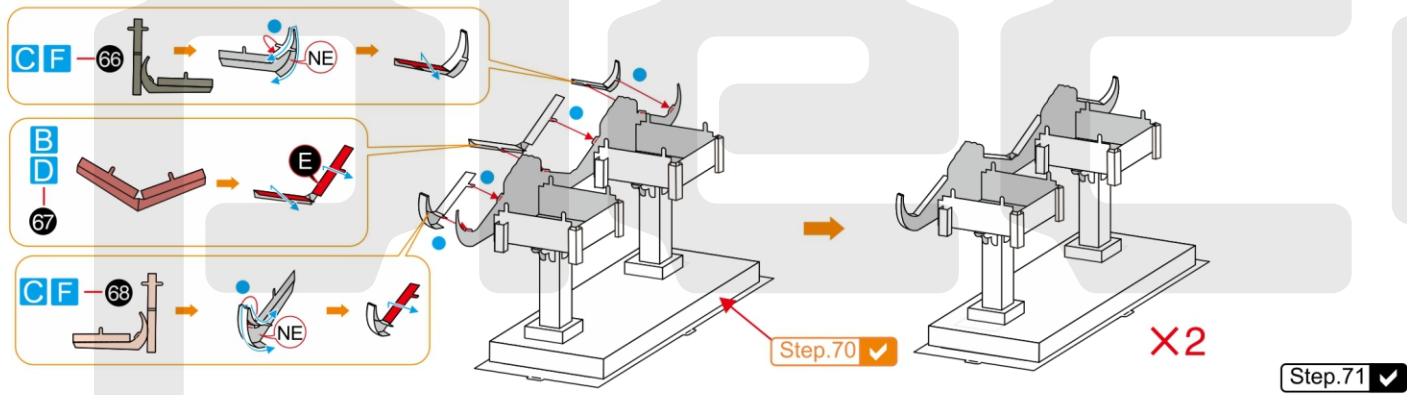

Step  
72

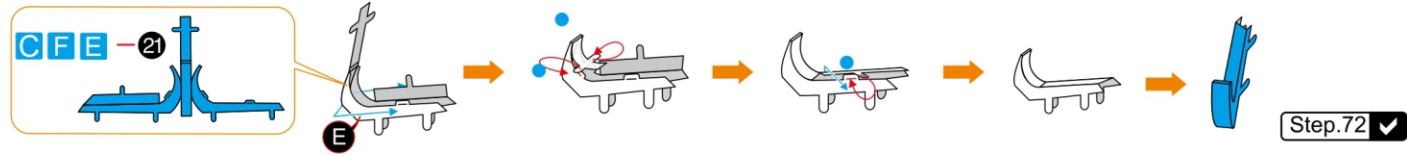

Step  
73

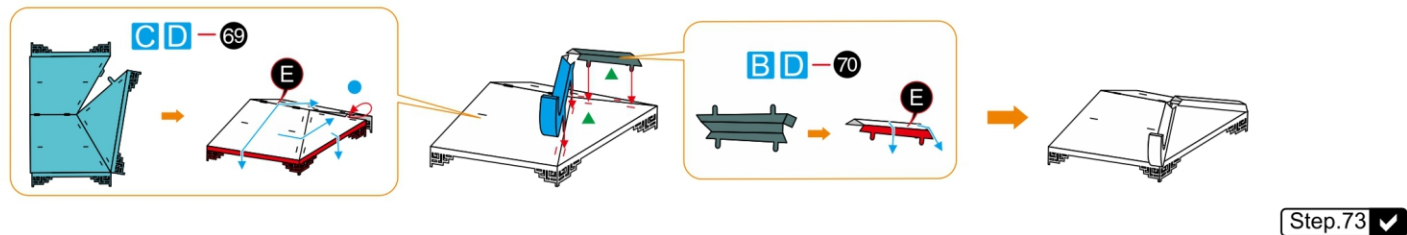

Step  
74

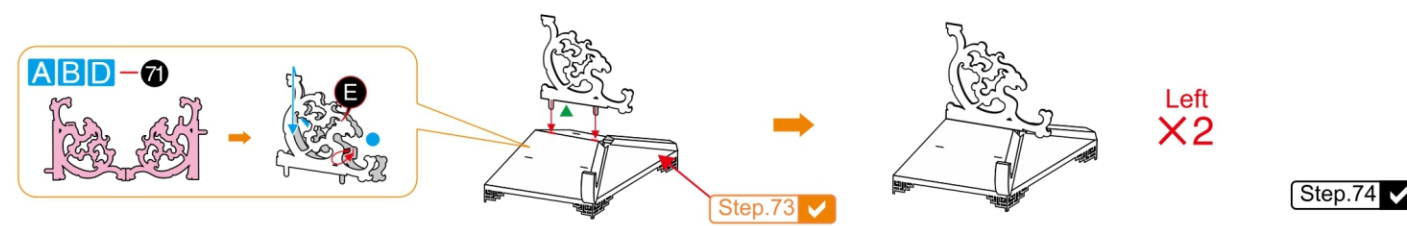

Step  
75

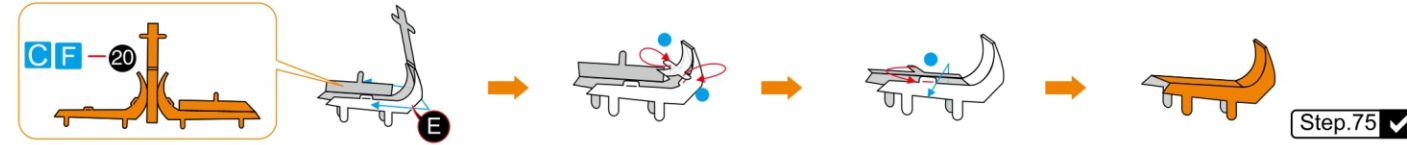

Step  
76

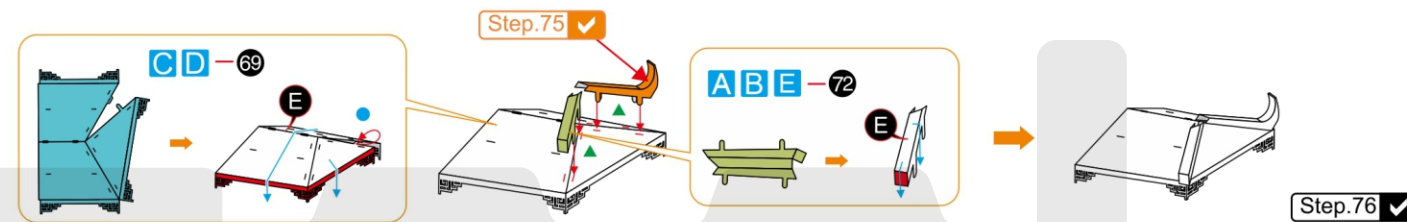

Step  
77

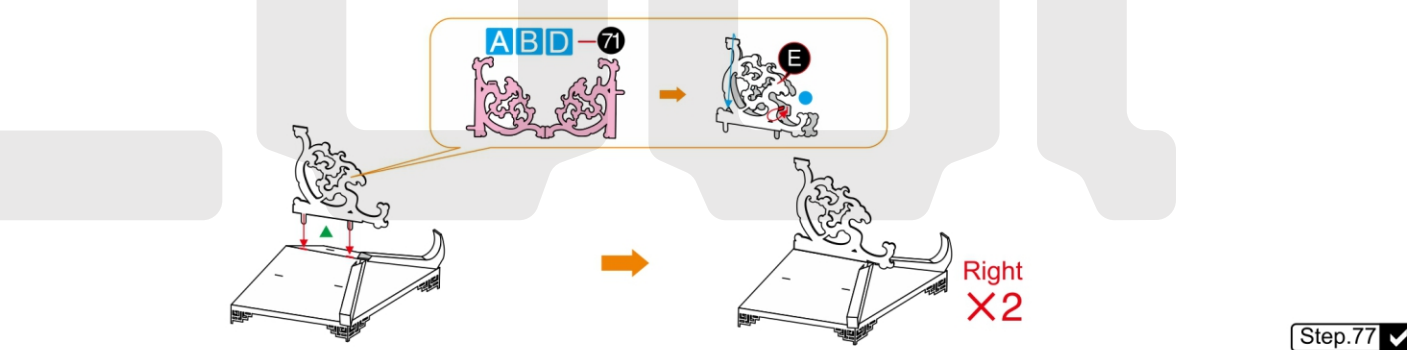

Step  
78

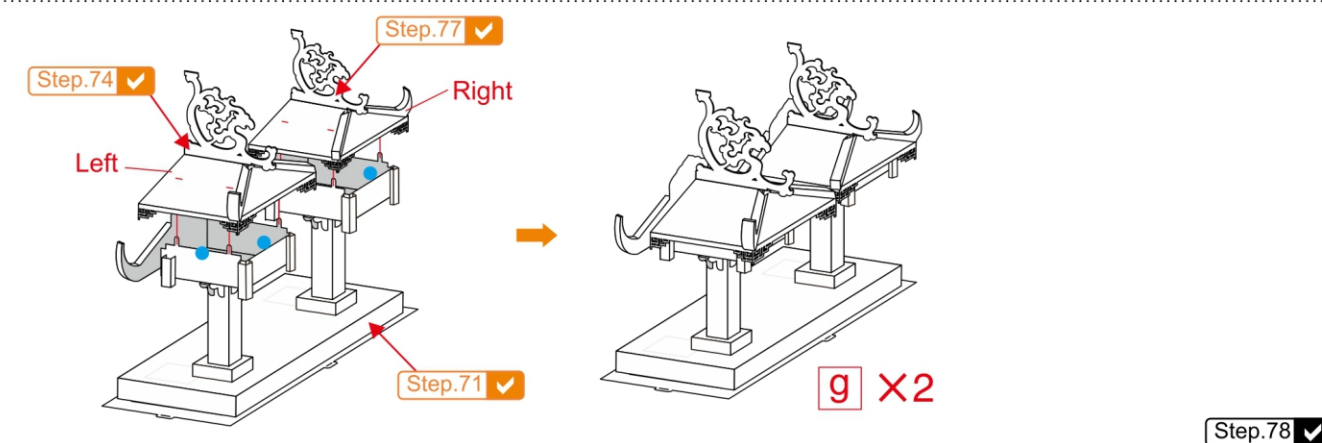

Left  
X2

Right  
X2

g X2

**Step**  
**79**

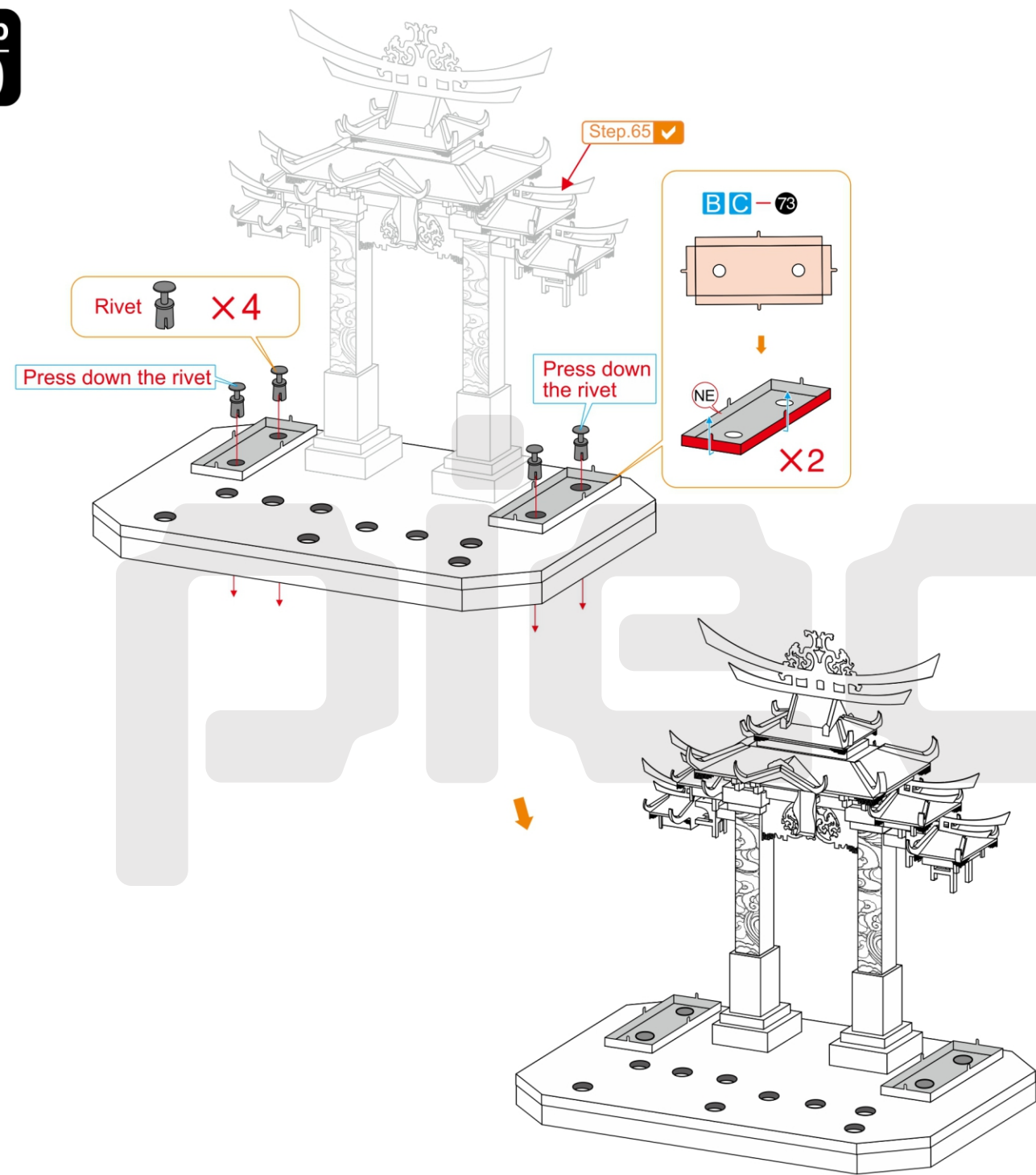

Step.79 ✓

**Step**  
**80**

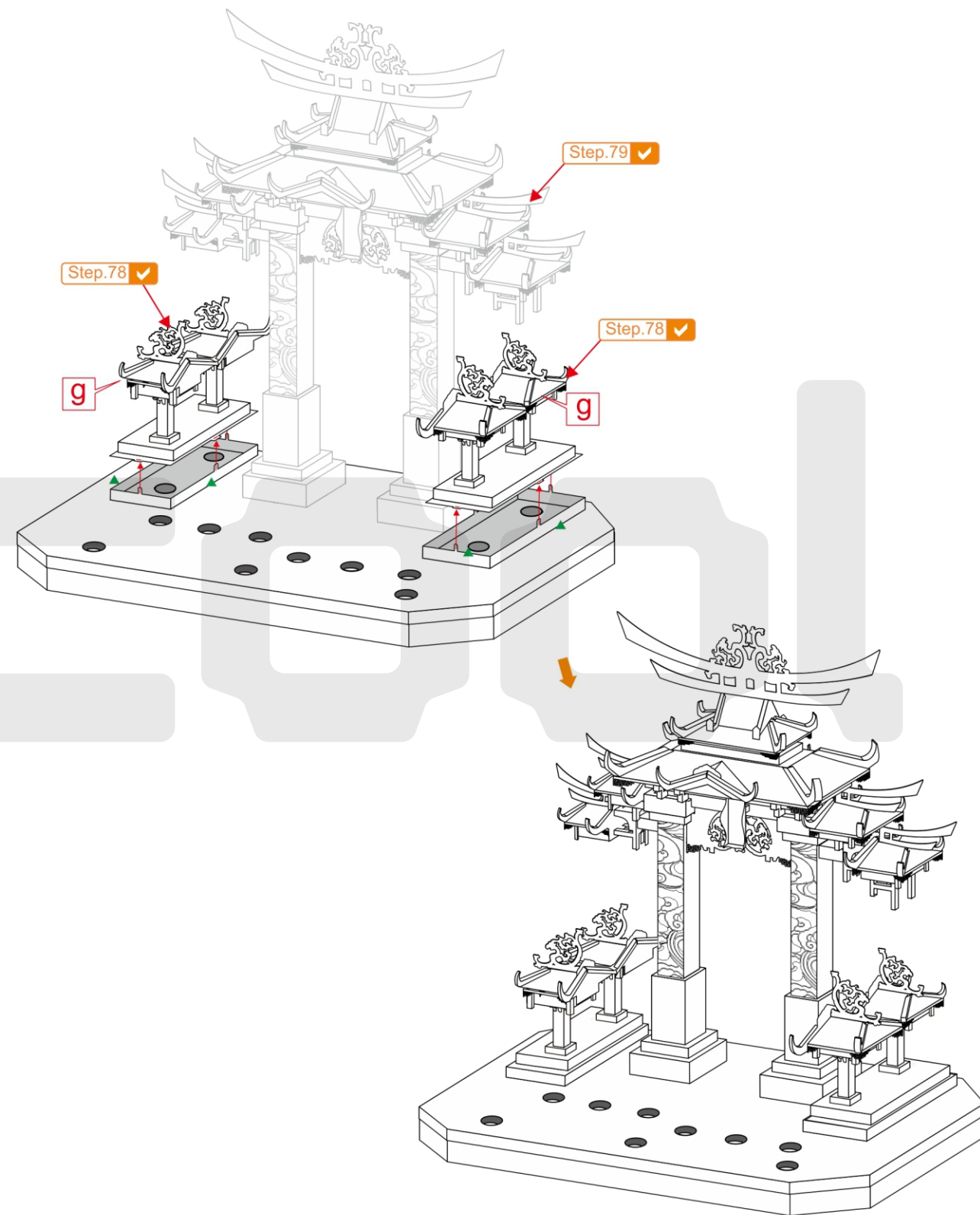

Step.80 ✓

Step 81

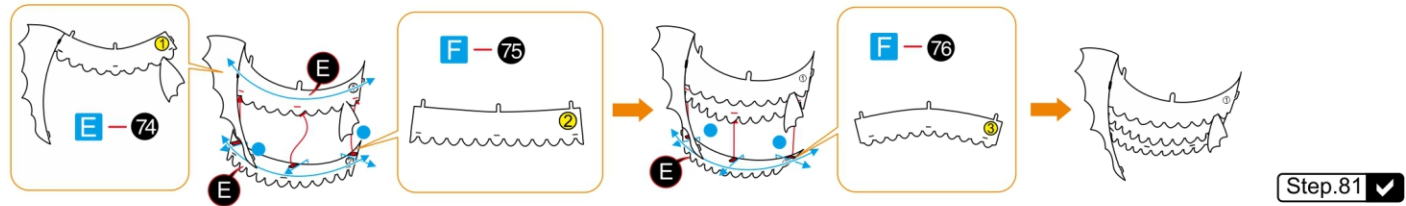

Step.81 ✓

Step 82



Step.82 ✓

Step 83

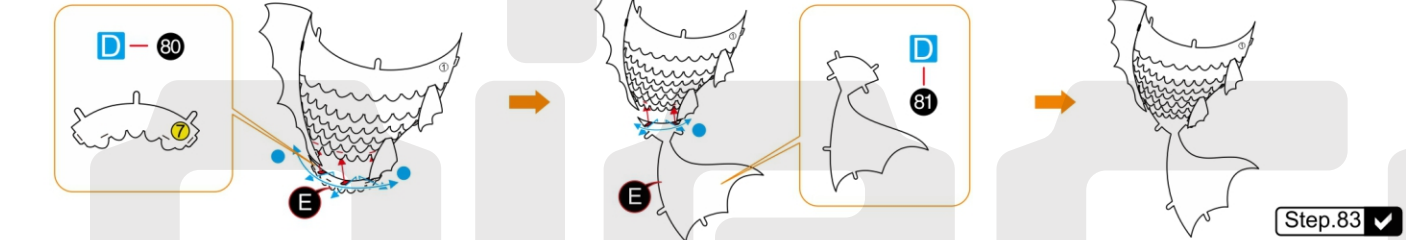

Step.83 ✓

Step 84

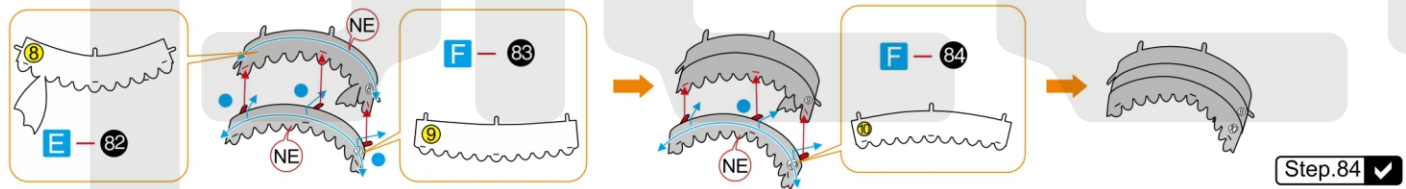

Step.84 ✓

Step 85

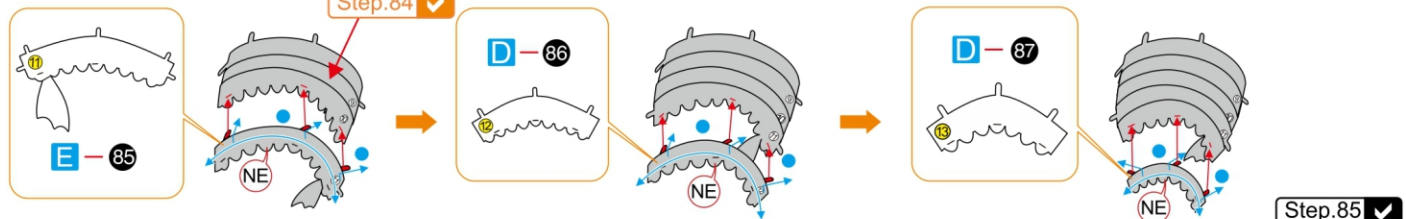

Step.85 ✓

Step 86

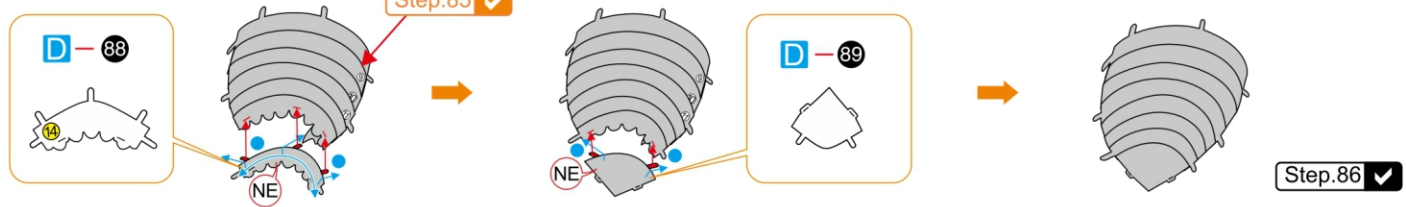

Step.86 ✓

Step 87

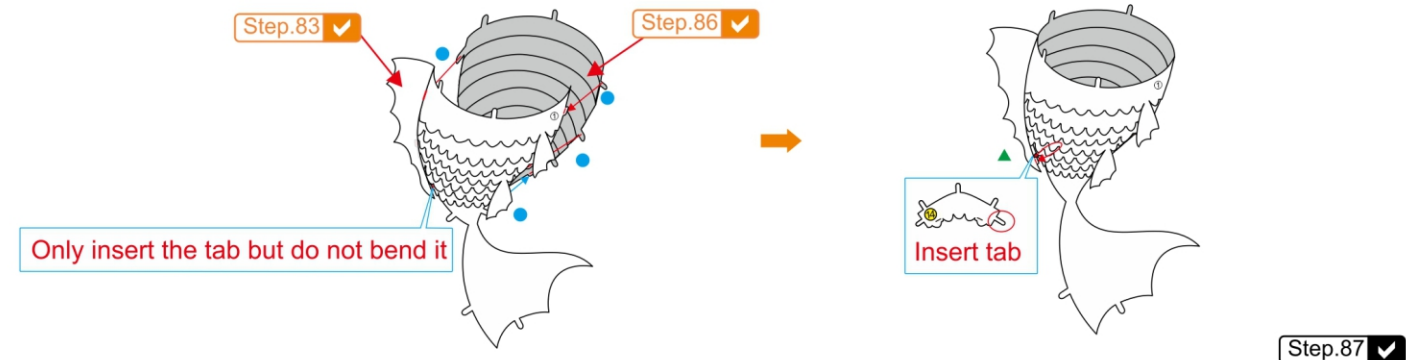

Step.87 ✓

Step 88

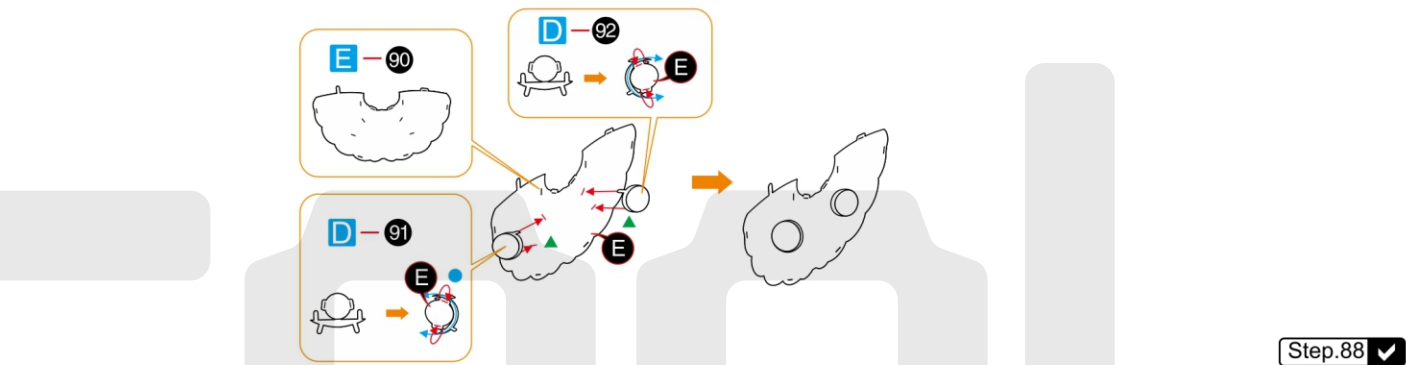

Step.88 ✓

Step 89

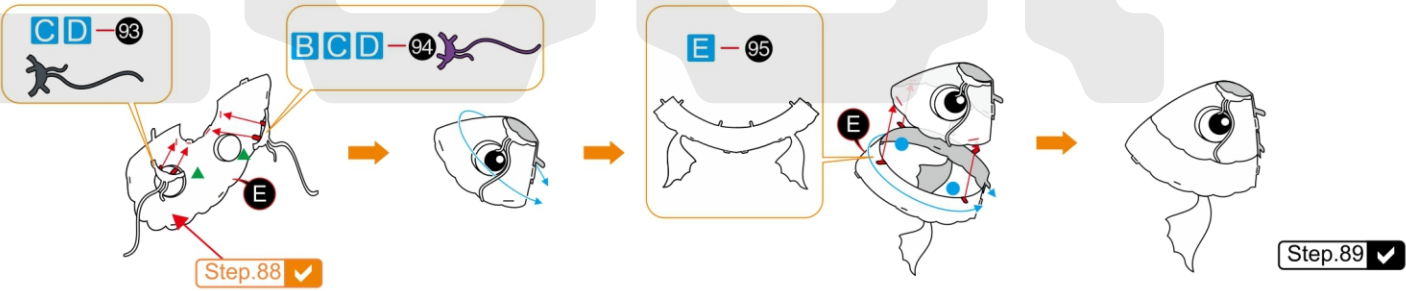

Step.89 ✓

Step 90

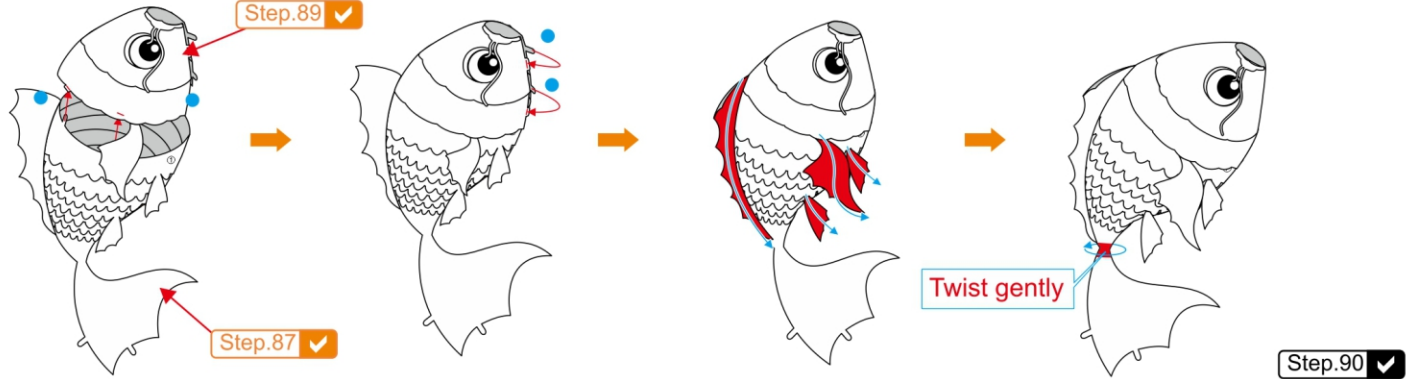

Step.90 ✓

**Step 91**

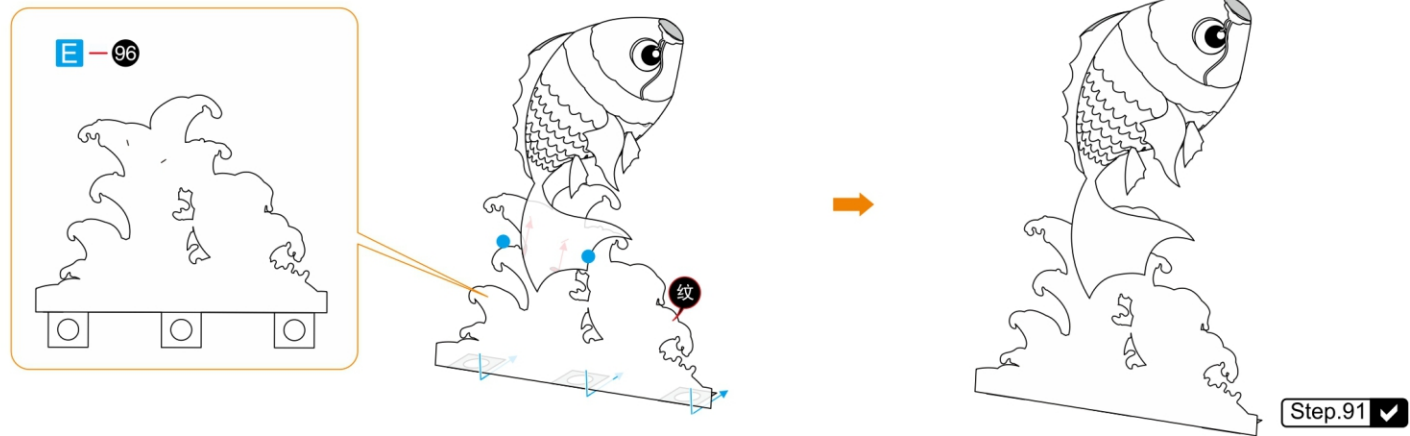

**Step 92**

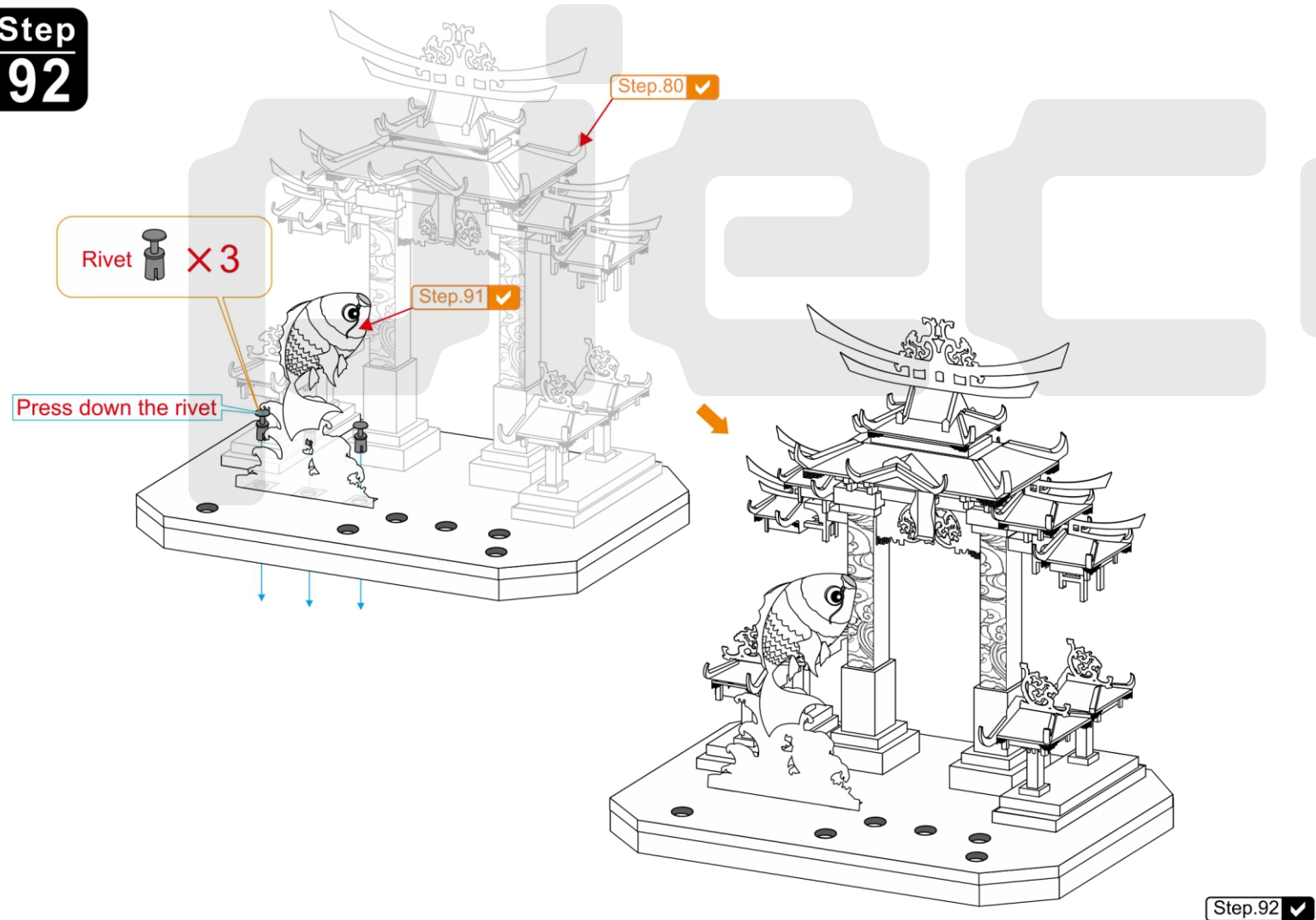

**Step 93**

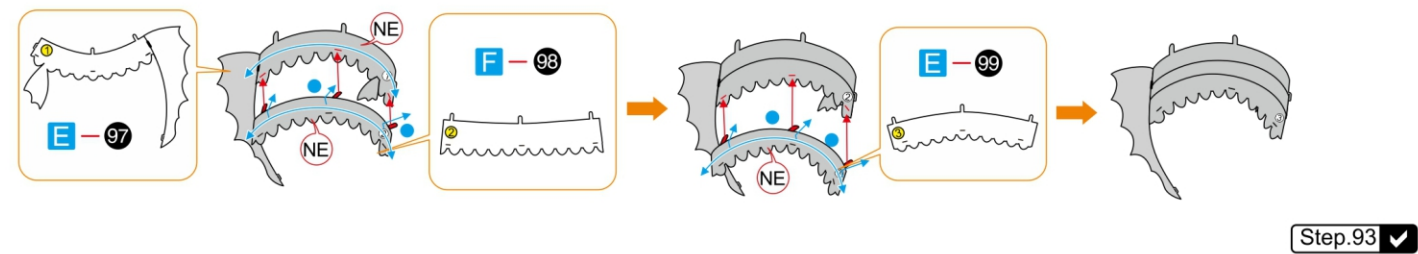

**Step 94**

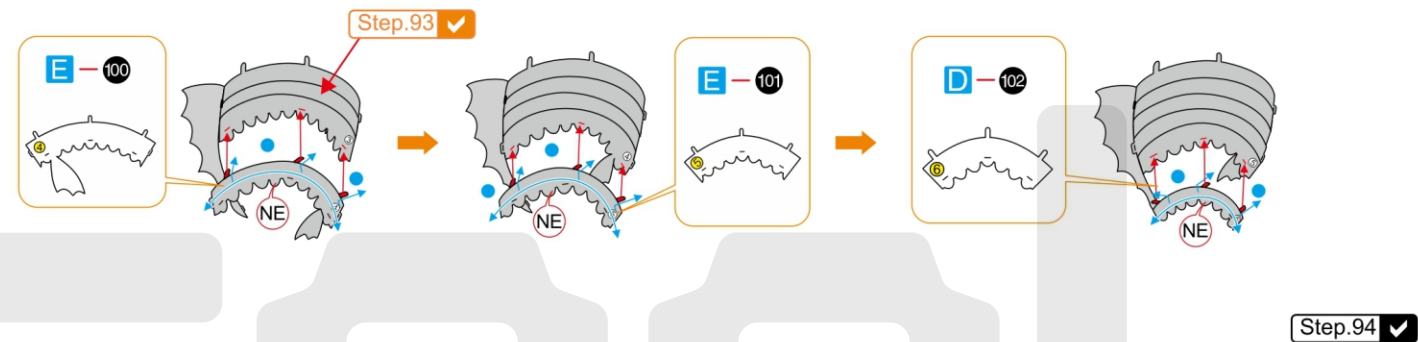

**Step 95**

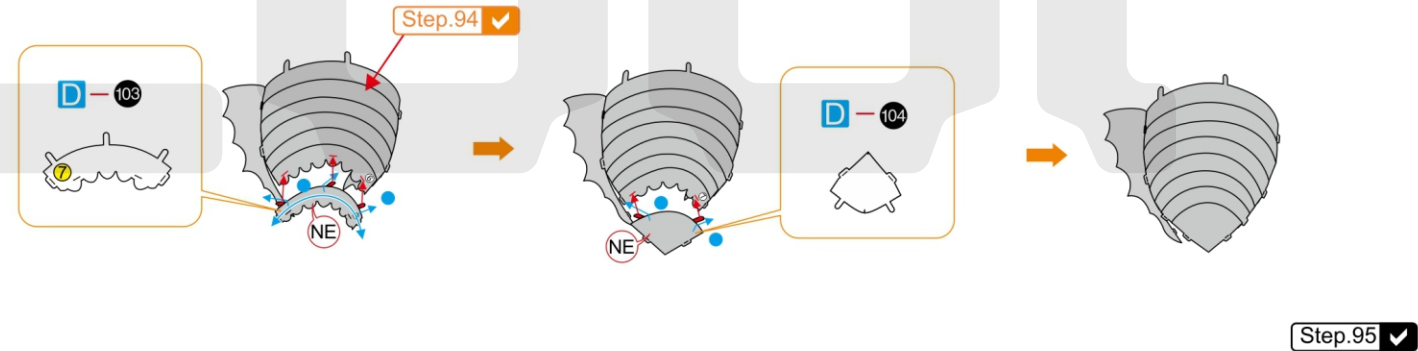

**Step 96**

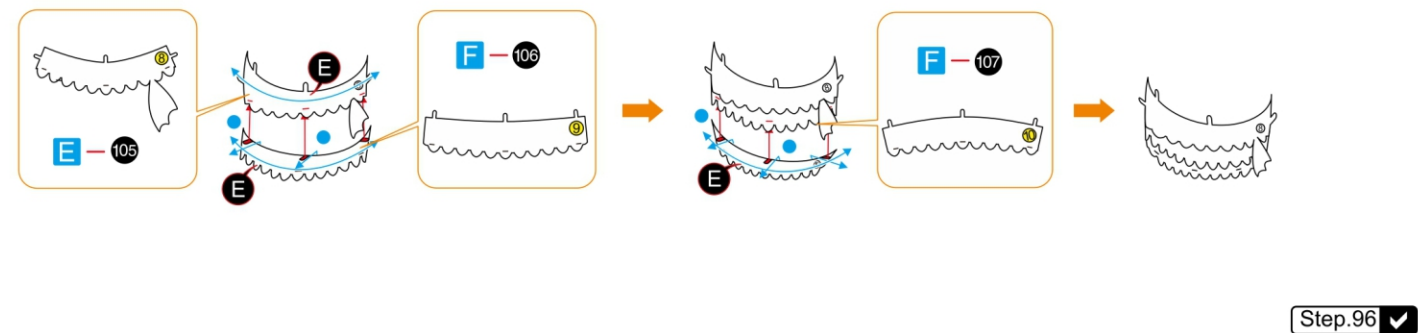

Step 97

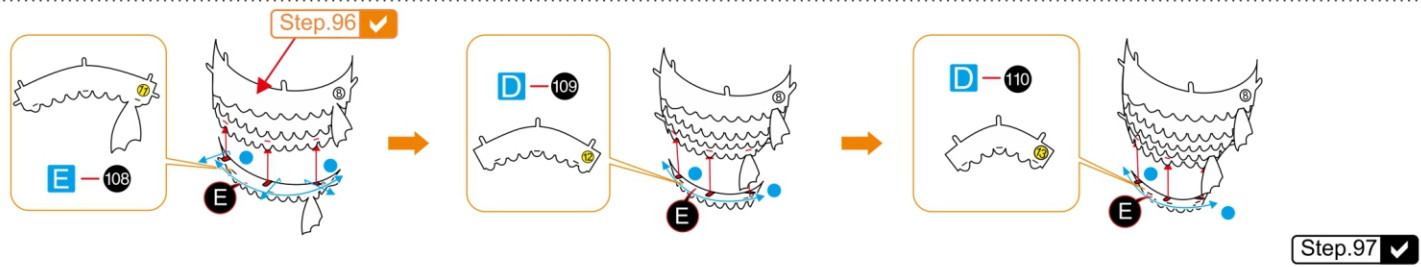

Step 98

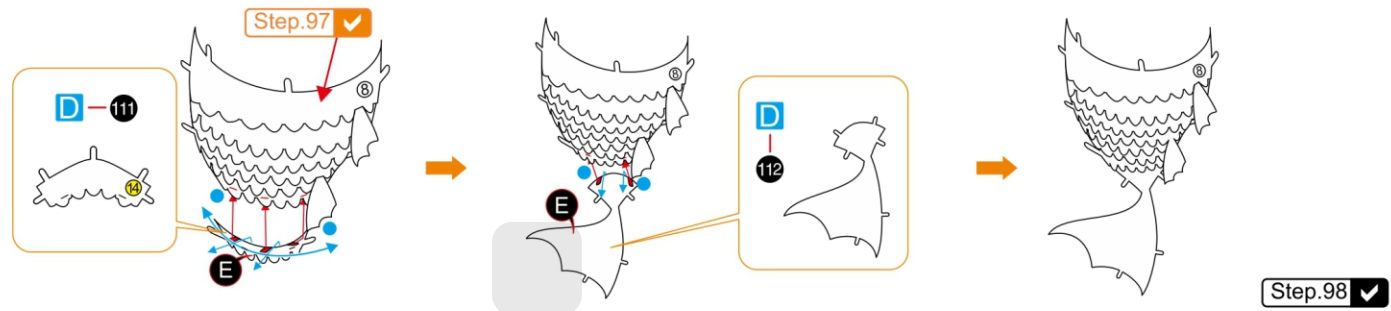

Step 99

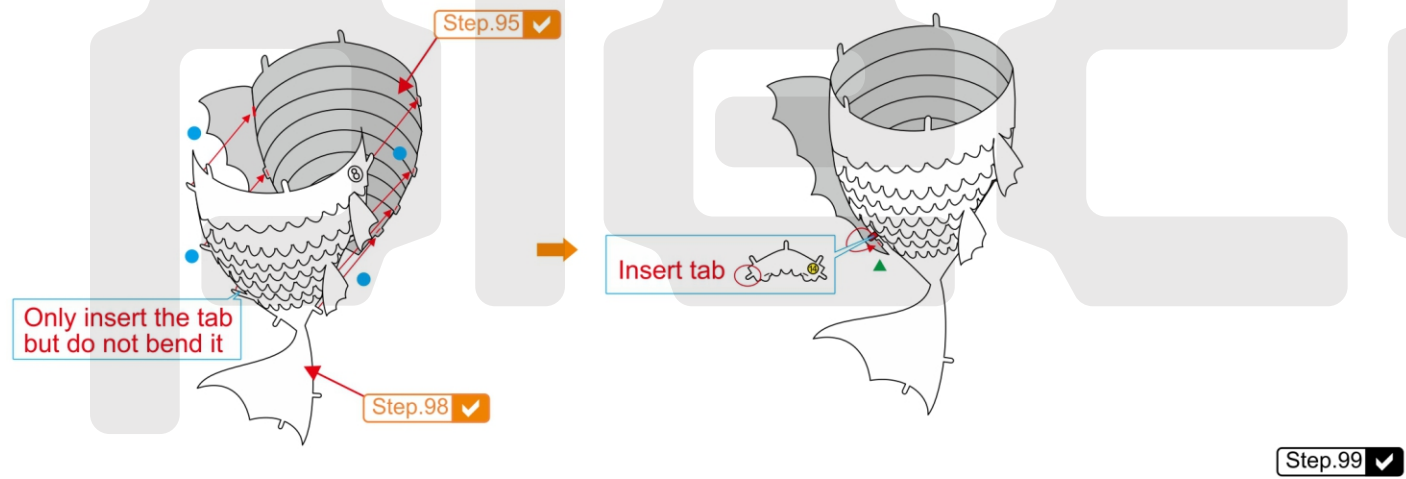

Step 100

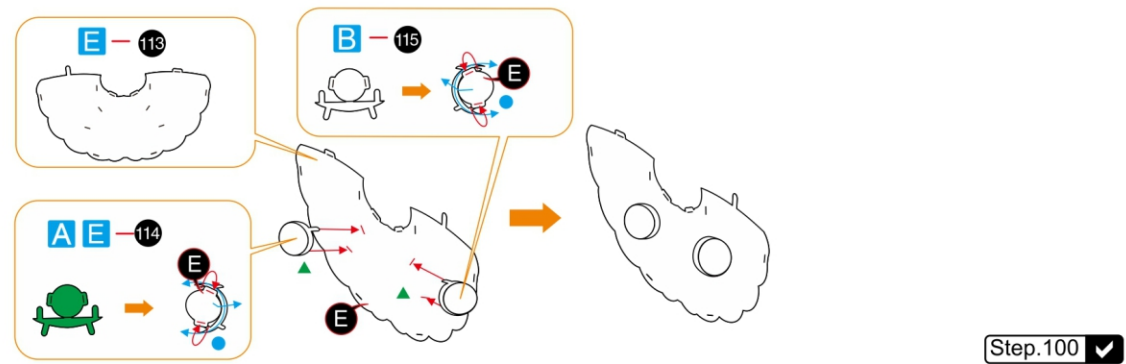

Step 101

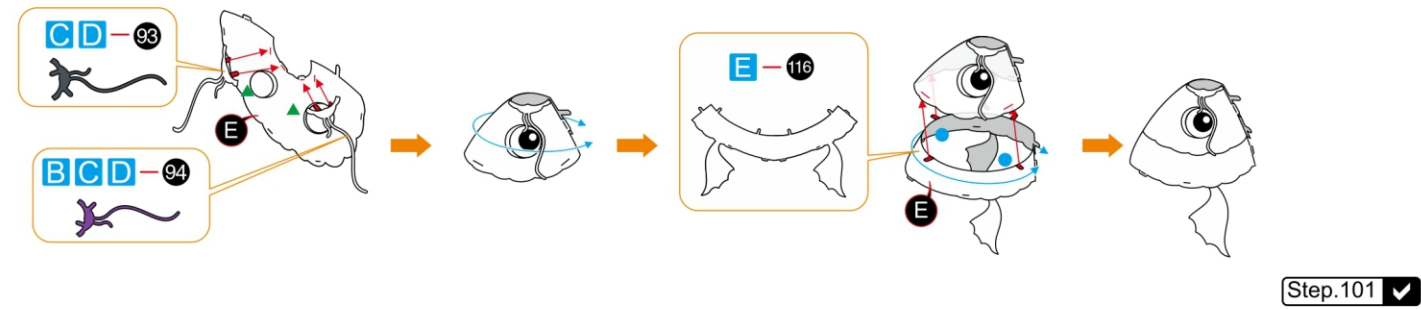

Step 102

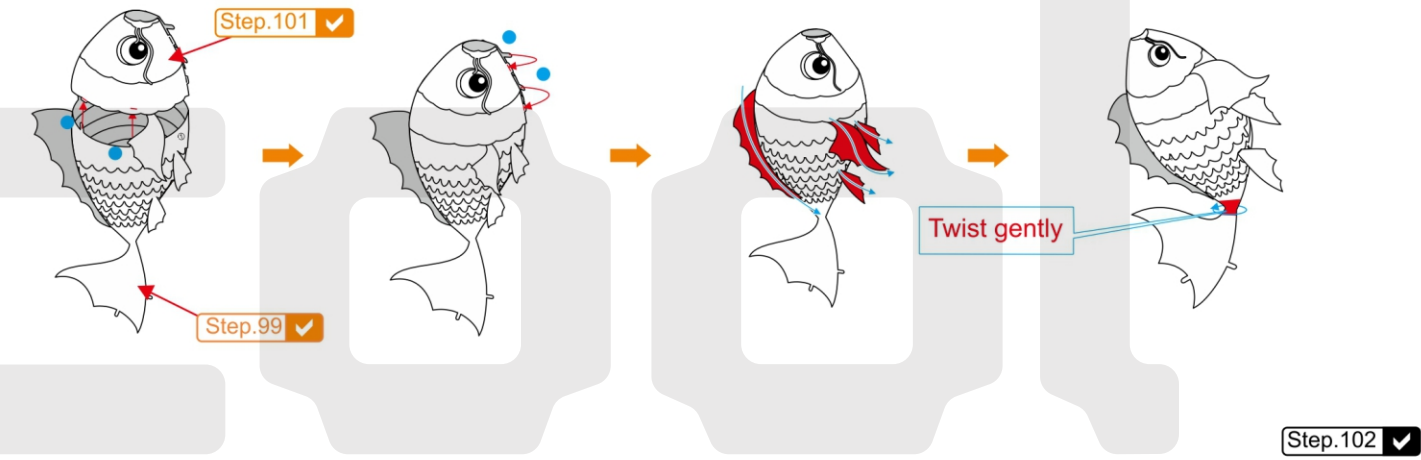

Step 103



**Step**  
**104**

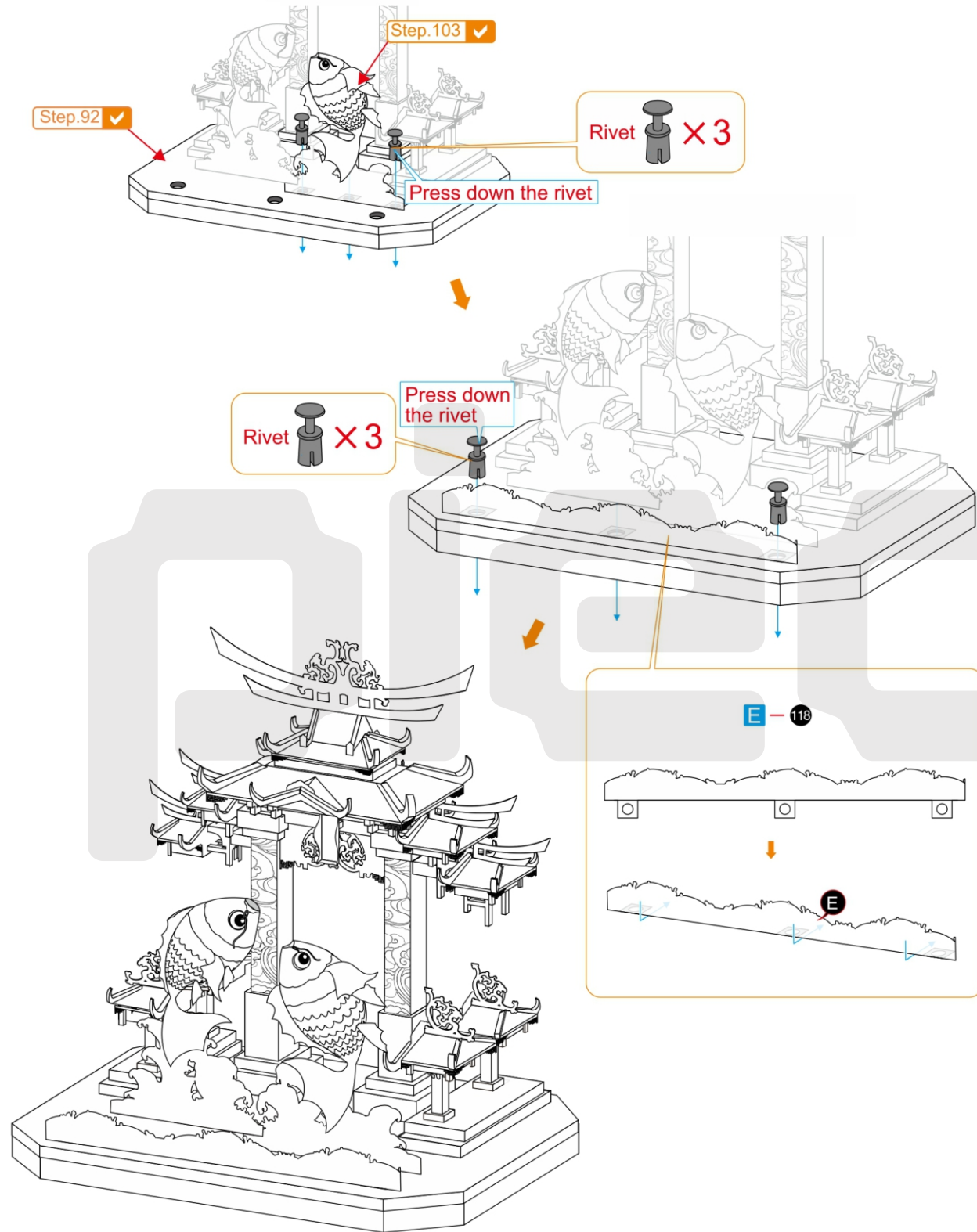

Step.104 ✓



