



**曾侯乙编钟**  
**CHIME-BELLS FROM THE TOMB OF**  
**MARQUIS YI OF ZENG STATE**  
**IP002-KR**

**拼 装 说 明 书**

**拼装提示 TIPS:**

本产品采用扣点与扣位卡扣拼折的拼装方式，未发生拼装损坏，无需使用胶水 

建议购买并使用拼酷正品拼装工具， T-SKQ05 水口钳  ， T-JZQ05 尖嘴钳  ， 拼装更省时省力，作品更精细美观！

请参照包装内说明书进行拼装，请勿反复拼折金属零件，以免损坏。

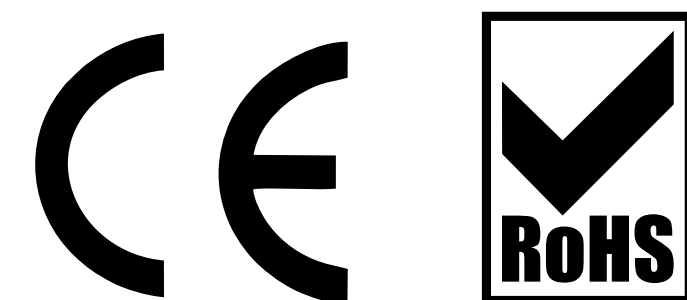

**AGES 14+**

本产品为金属制品，14岁以下需由成人陪同完成！

## 曾侯乙编钟 IP002

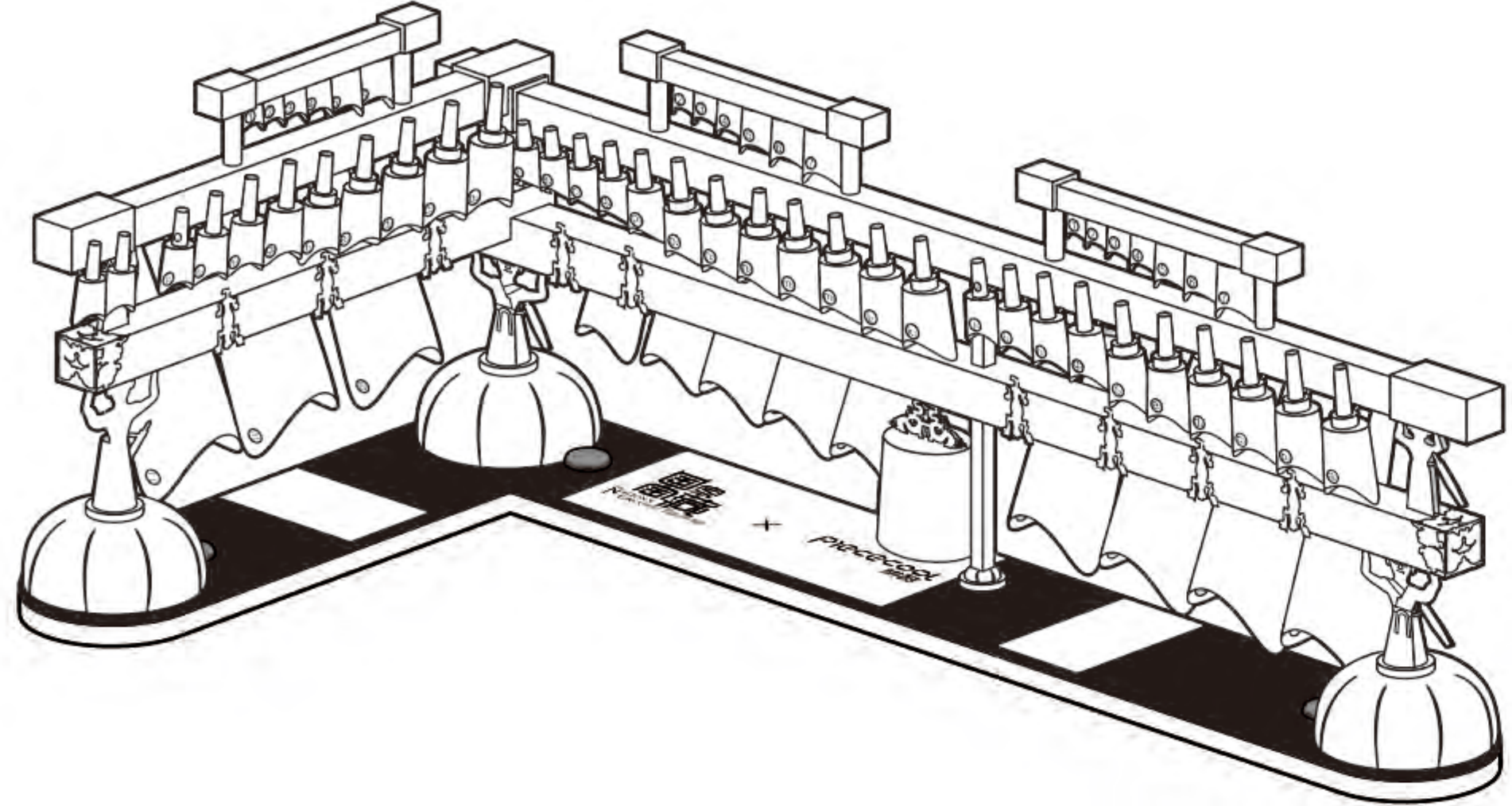

CP-ASSY-IP002-A2-20200310

### 拼前需知

**⚠️ 组装时请小心处理金属零件，以防划伤**

#### • 准备工具：



建议使用拼酷正品拼装工具（水口钳、尖嘴钳），拼装时更省心、省力，拼装后作品更精细、美观！

#### • 拼装方法：

##### a. 取下零件



使用水口钳剪断金属零件上的水口，将需要的金属零件从金属片板上取下。

##### b. 识别零件

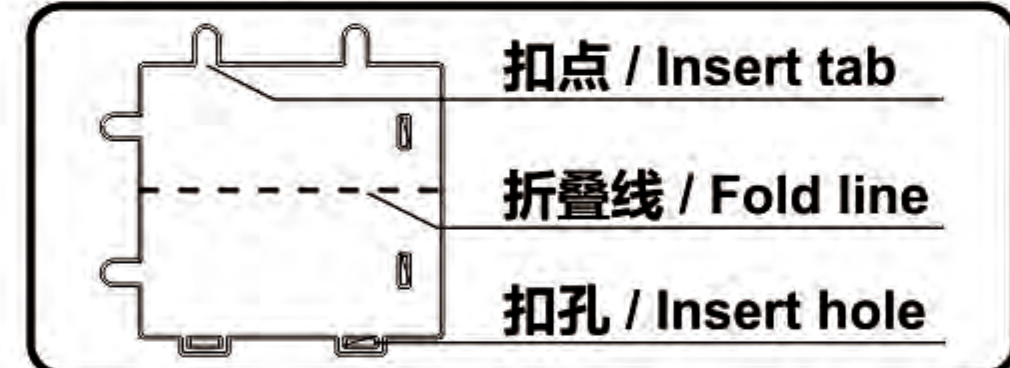

识别金属零件上的扣点、折叠线、扣孔的样子。

##### c. 折叠零件

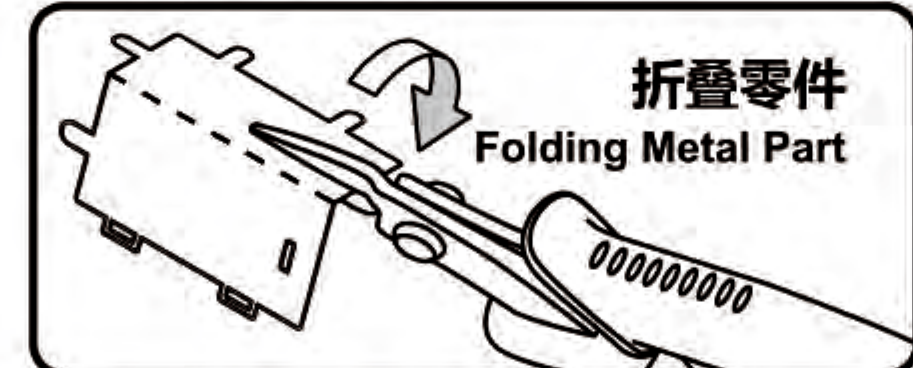

使用尖嘴钳，参照拼装说明书将金属零件折成形状。

##### d. 固定零件



● 插入扣孔，平折 90°

▲ 插入扣孔，旋转 90°

#### • 注意事项：

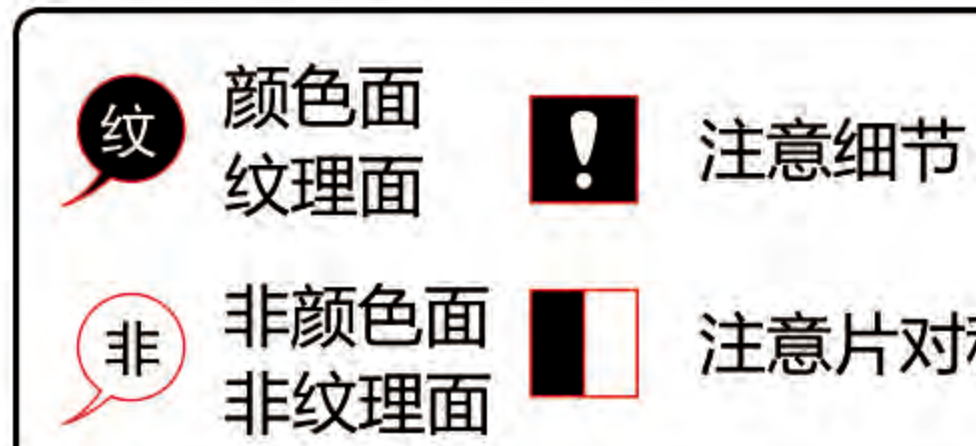

剪金属零件时请剪零件“水口位”，请勿将“扣点”当成“水口位”剪下，每次剪零件时请仅剪当前步骤的零件，切勿一次性将所有零件全部剪下，避免丢失；  
当遇到折叠线的零件，请注意金属片的正反面及拼折方向，请按照说明书说明的方向，轻剪慢折，最好一次折叠完成，请勿反复折叠，避免零件损坏。

### Step 21

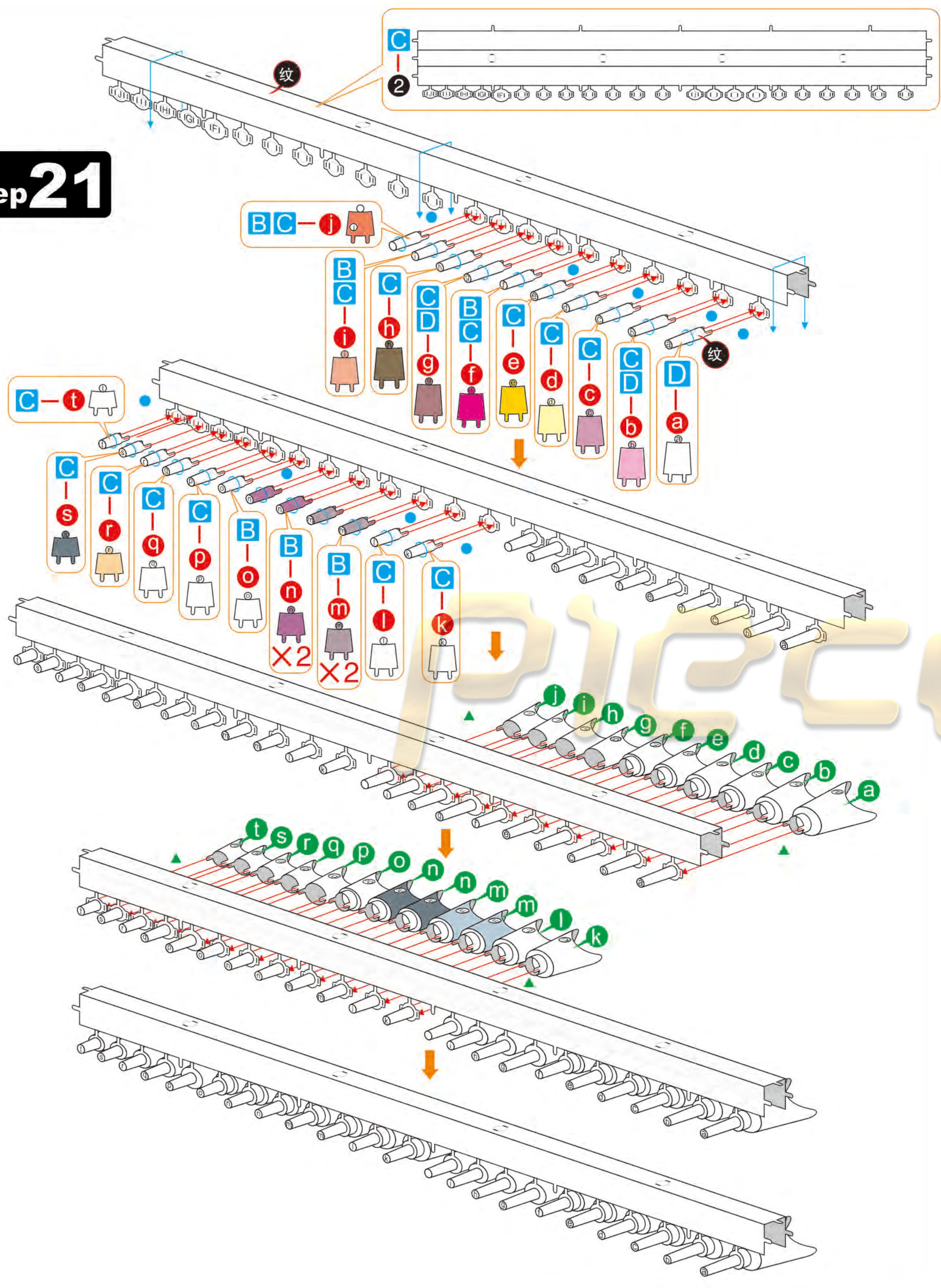

### Step 22



### Step 23



### Step 24



### 拼装步骤

**Step 1**

**Step 2**

**Step 3**

**Step 4**

**Step 5**

**Step 6**

**Step 7**

**Step 8**

**Step 9**

**Step 10**

**Step 11**

**Step 12**

**Step 13**

**Step 14**

**Step 15**

**Step 16**

**Step 17**

**Step 18**

**Step 19**

**Step 20**

**Step 25**

**Step 26**

**Step 27**

**Step 28**

**Step 29**

**Step 30**

请按照零件上数字1到7进行排列组装

**Step 31**

请按照零件上数字2到7进行排列组装

**Step 32**

请按照零件上数字1到6进行排列组装

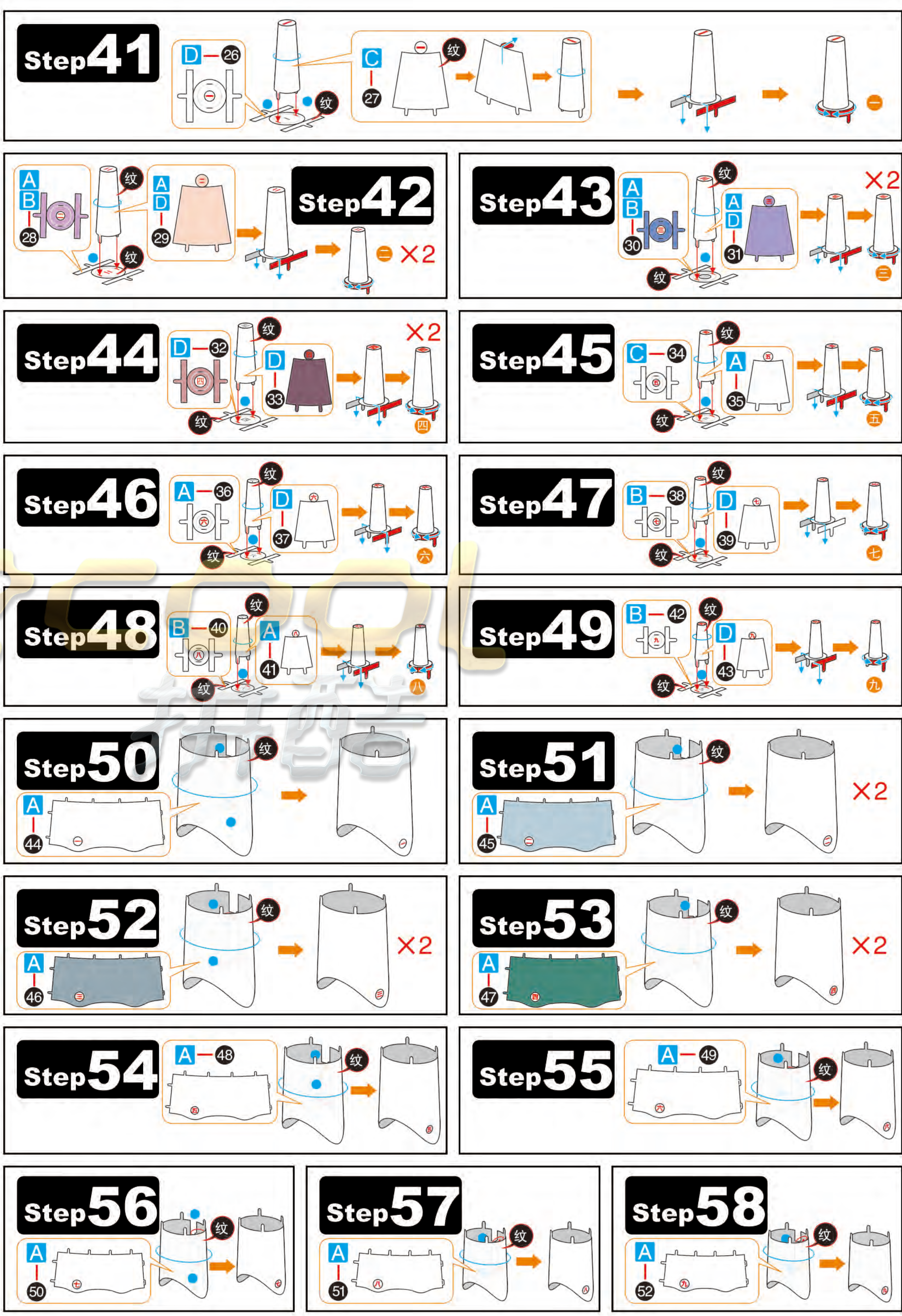
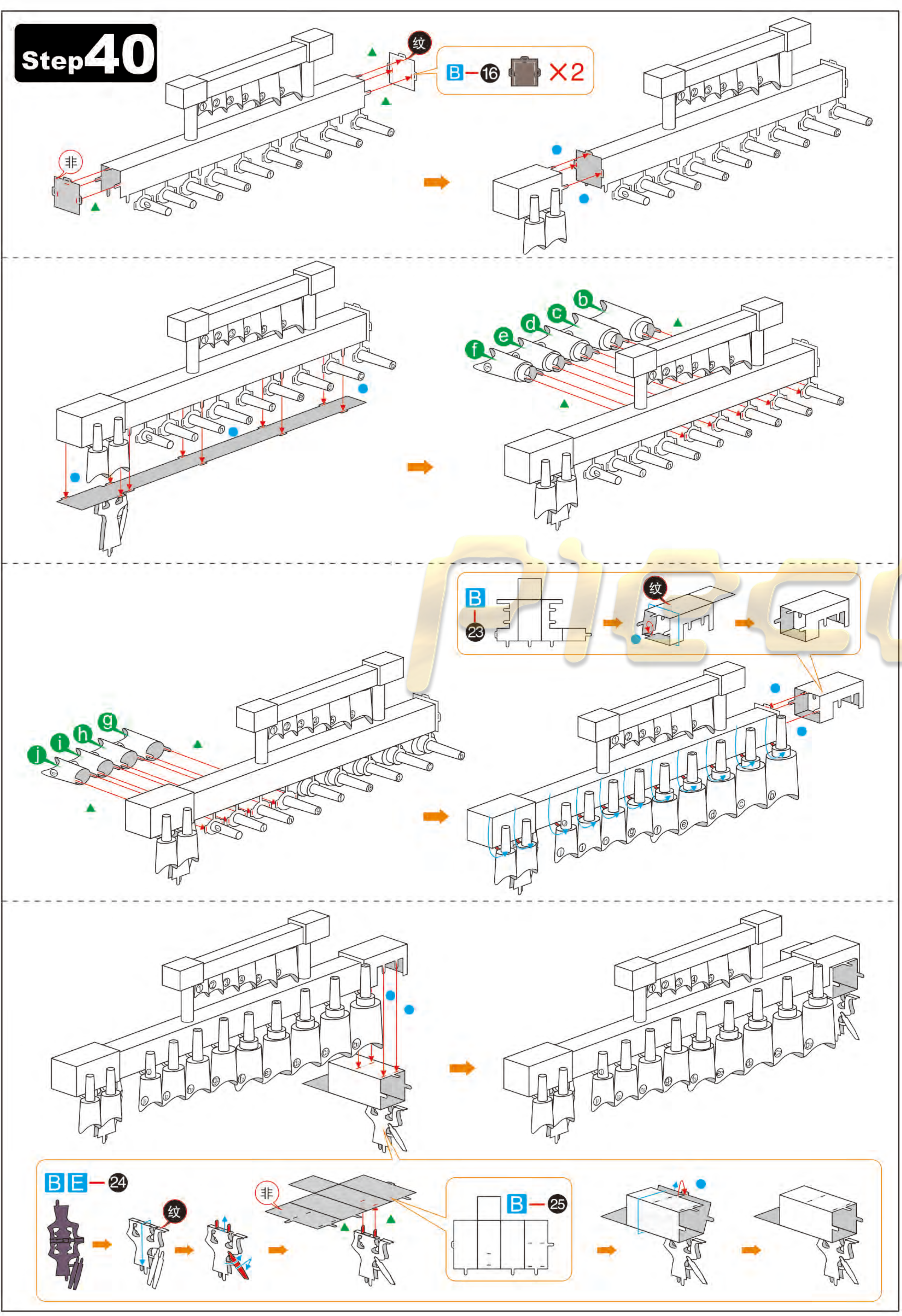
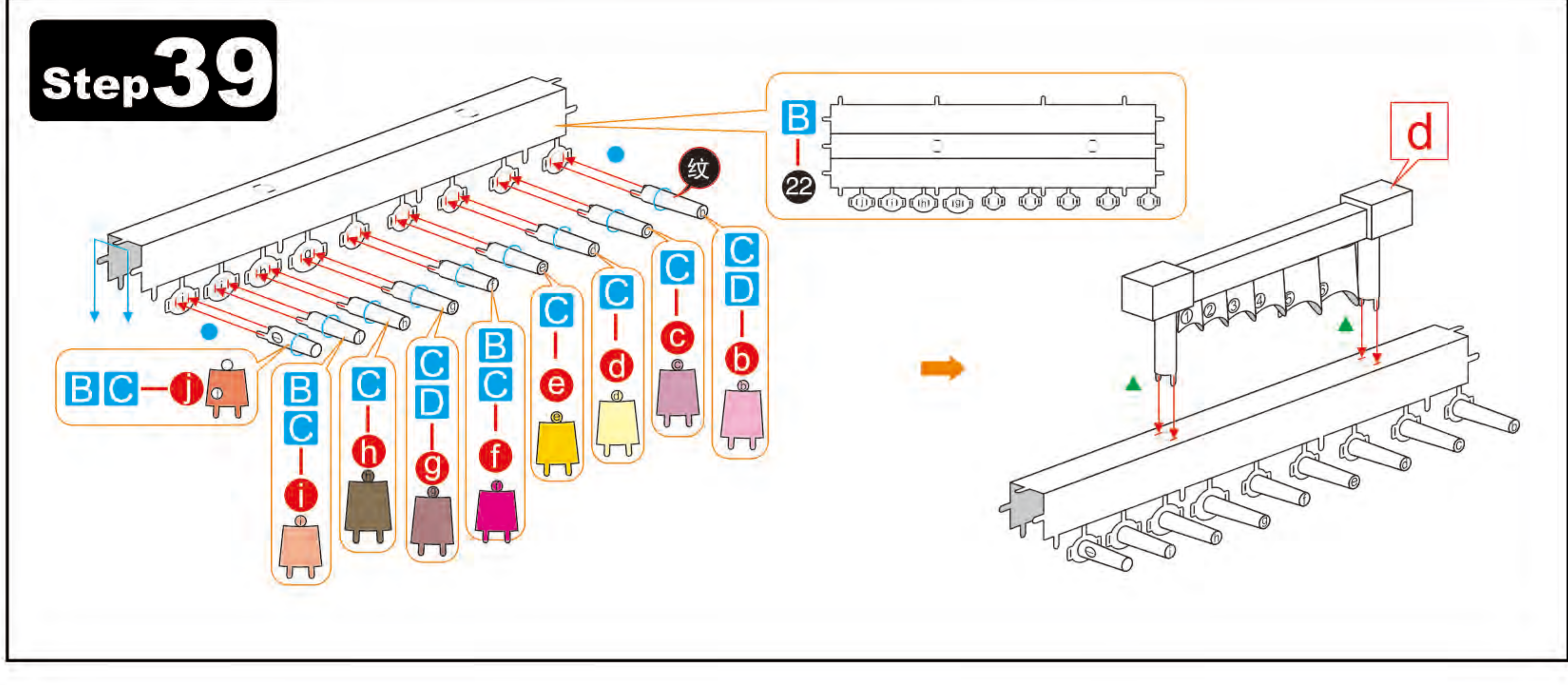
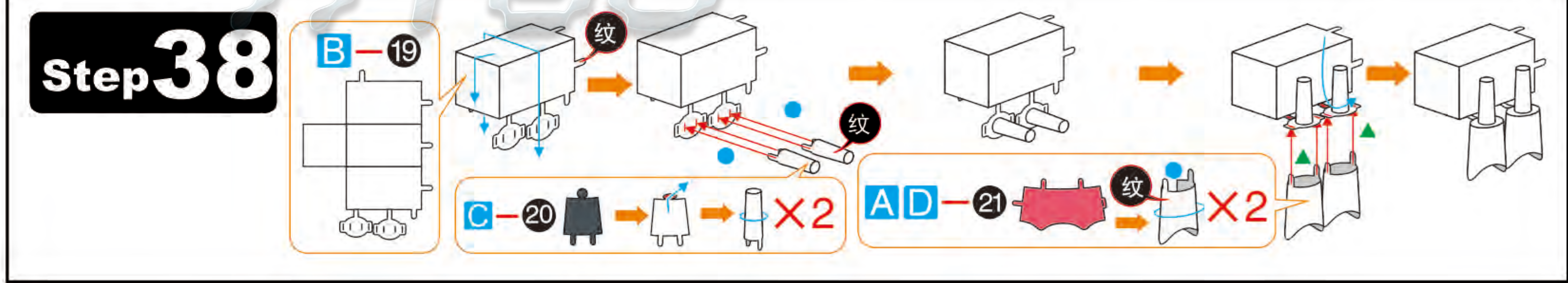
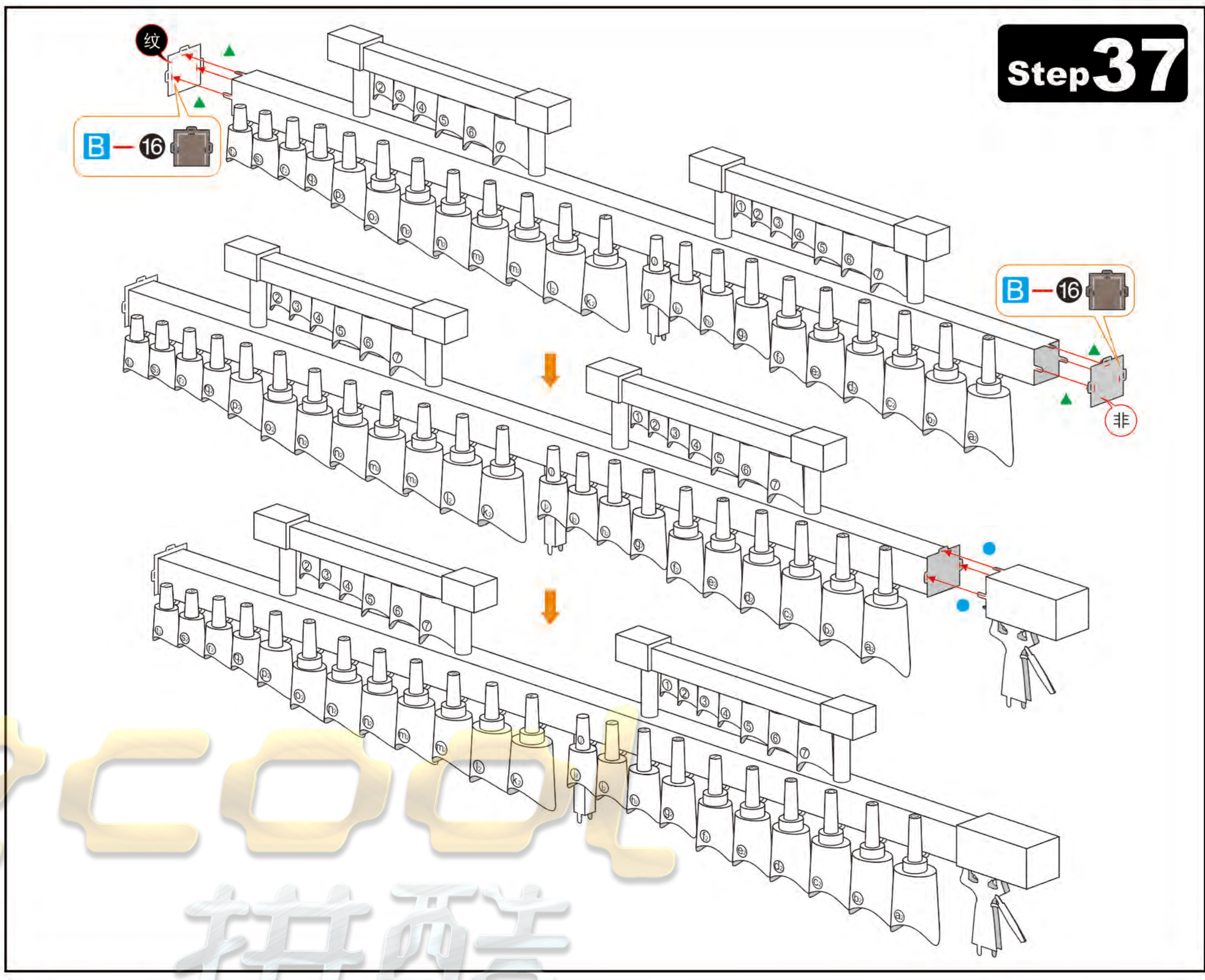
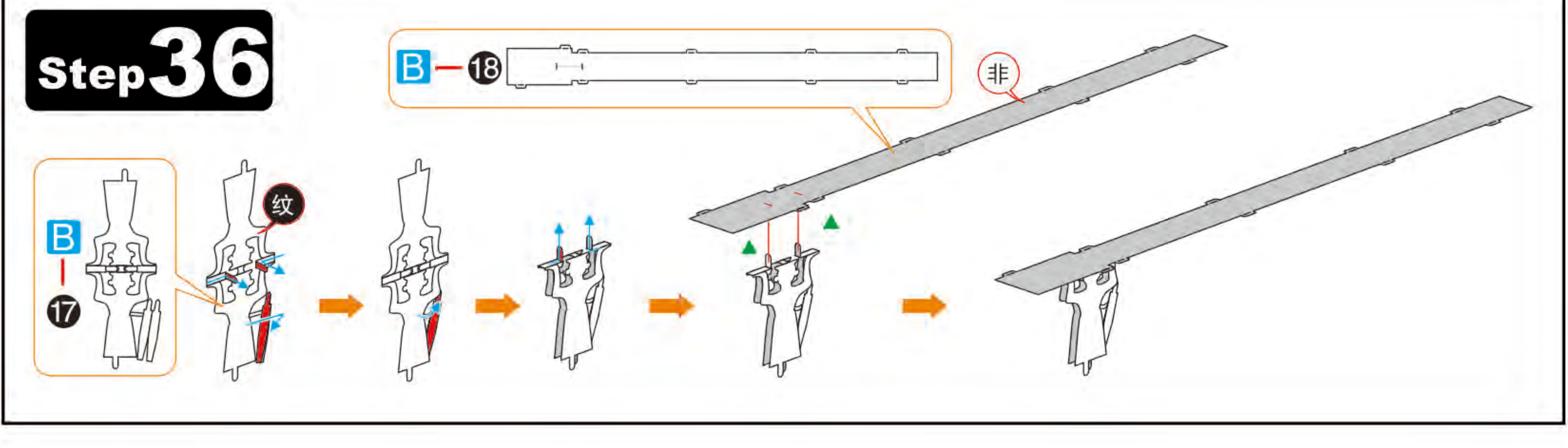
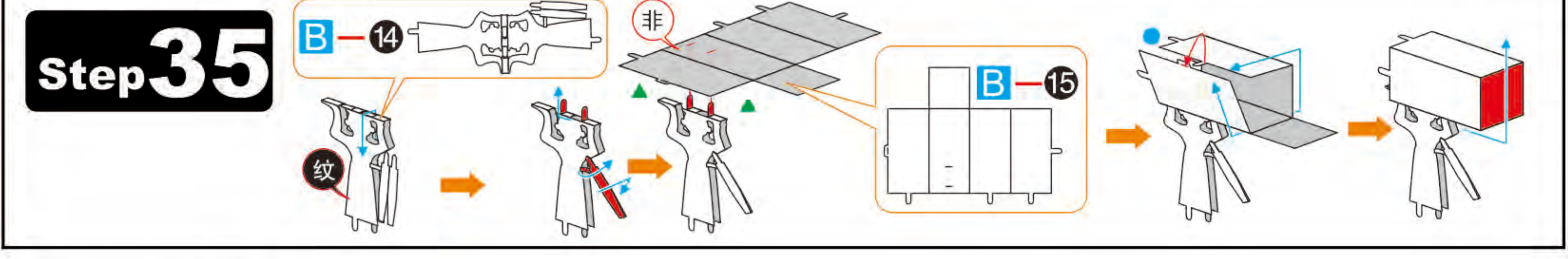
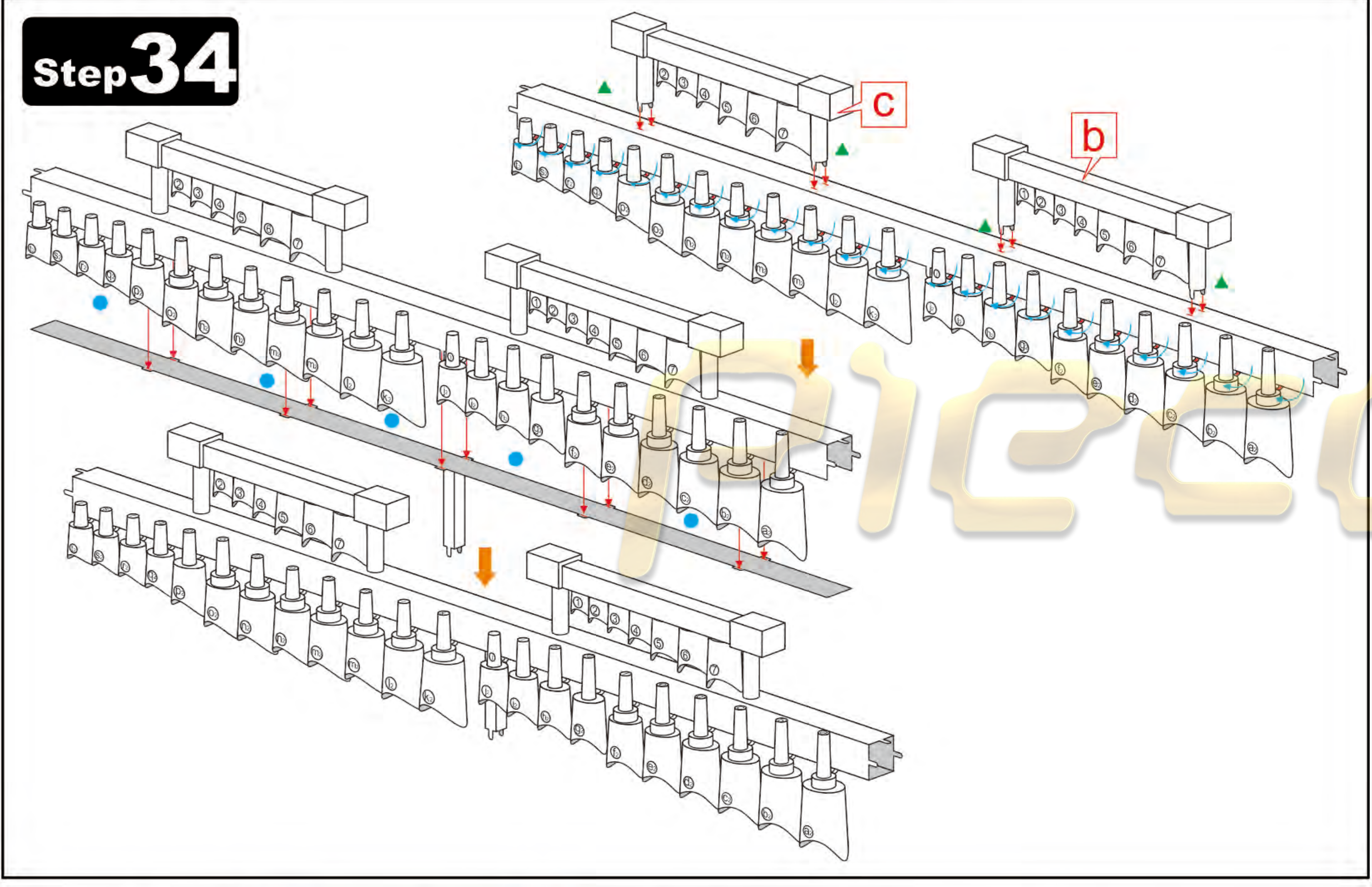
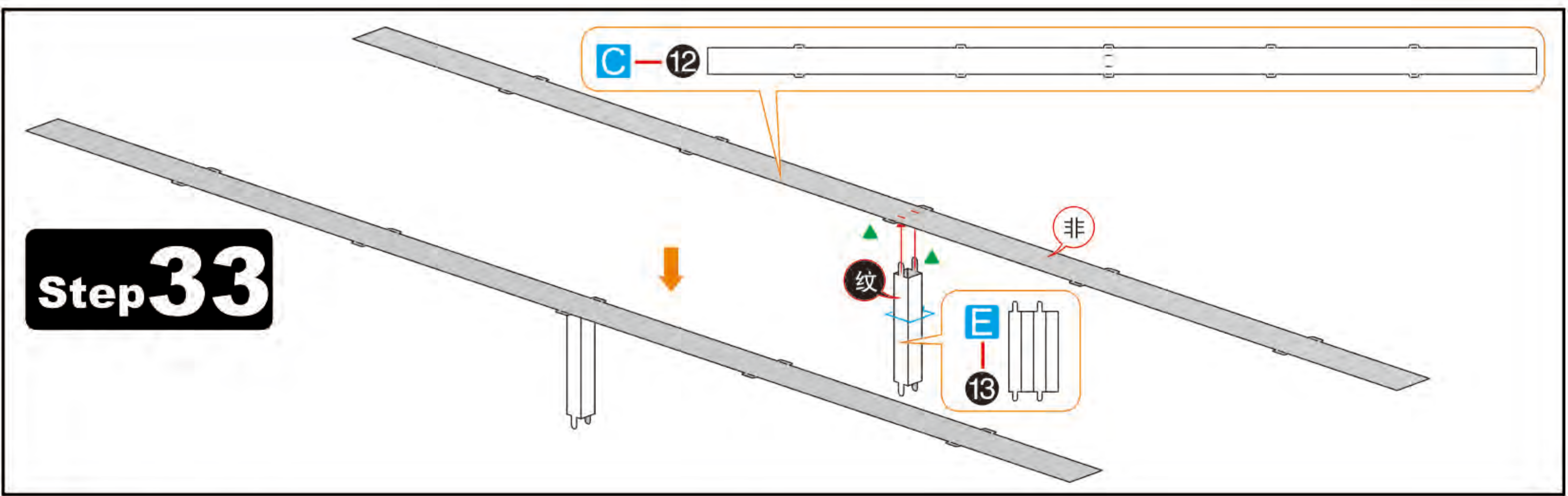

Step 59

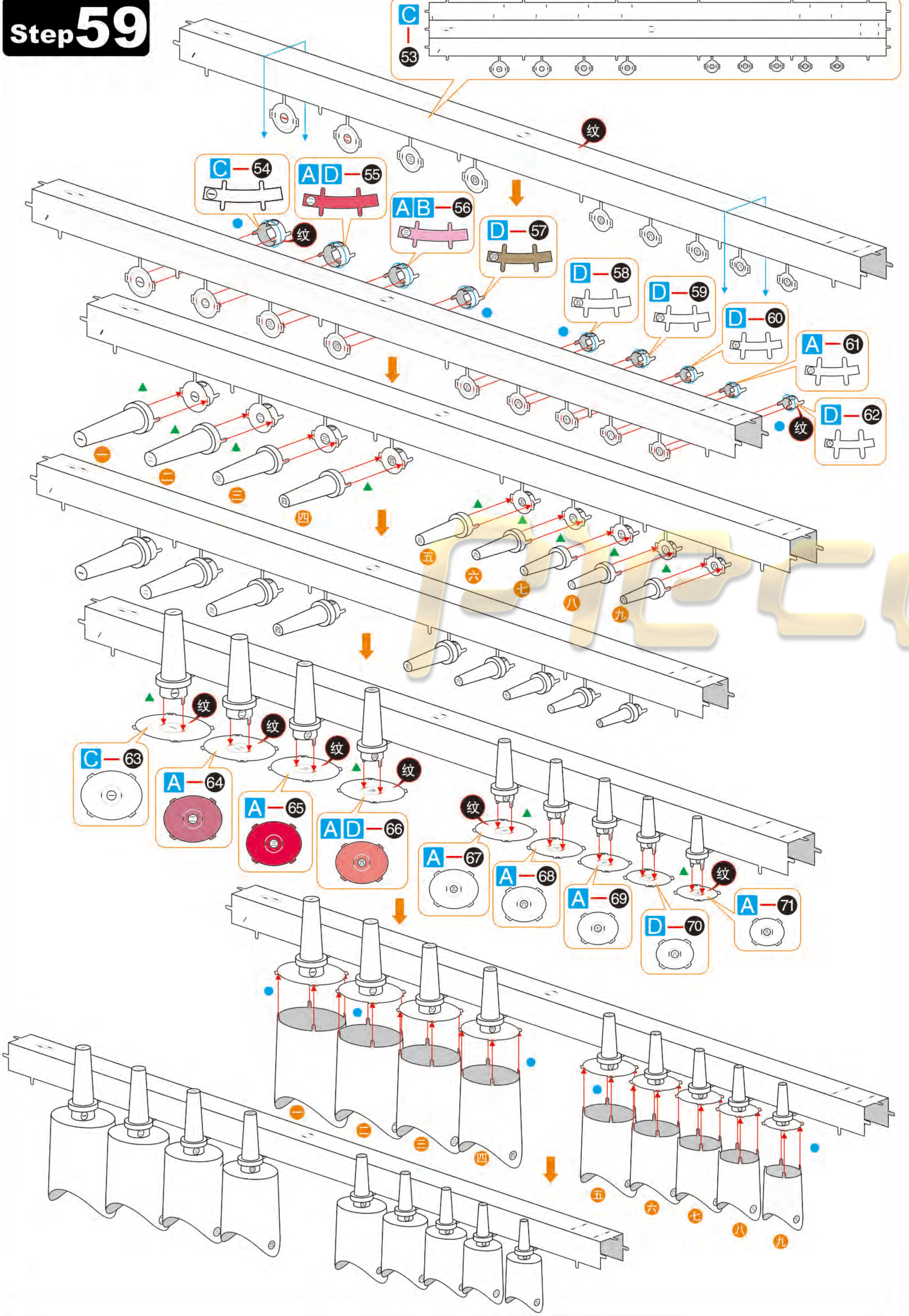

Step 60

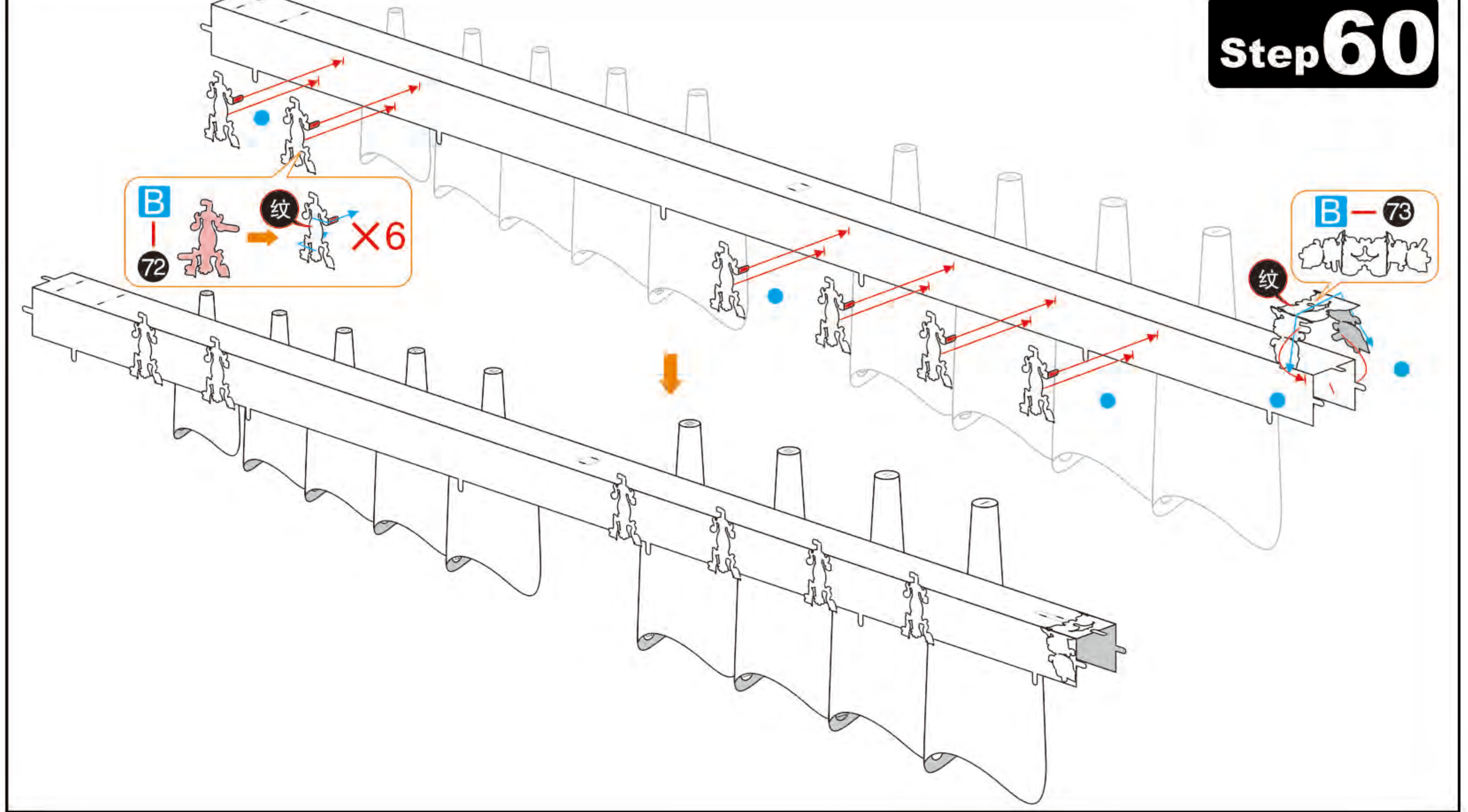

Step 61

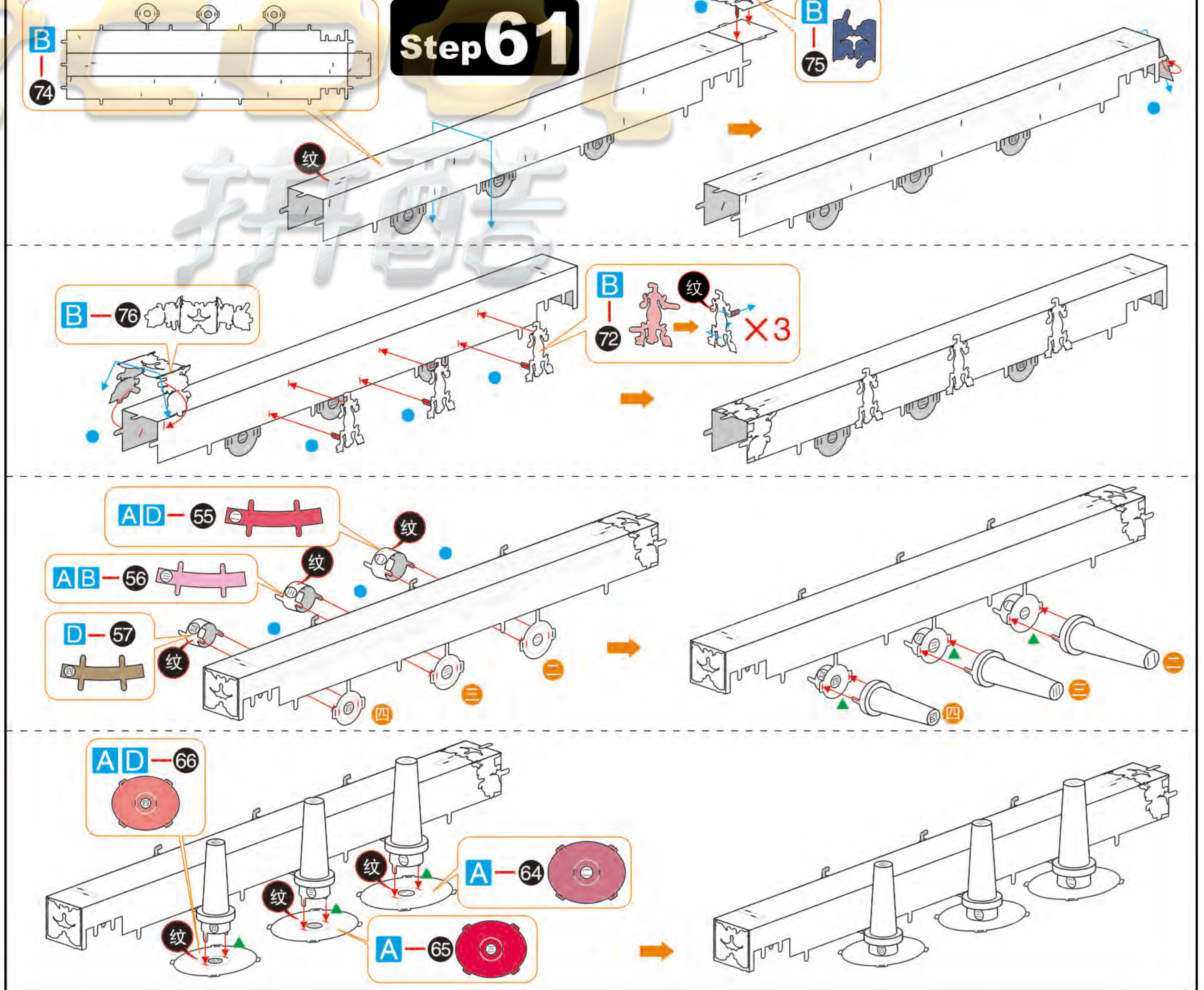

Step 62

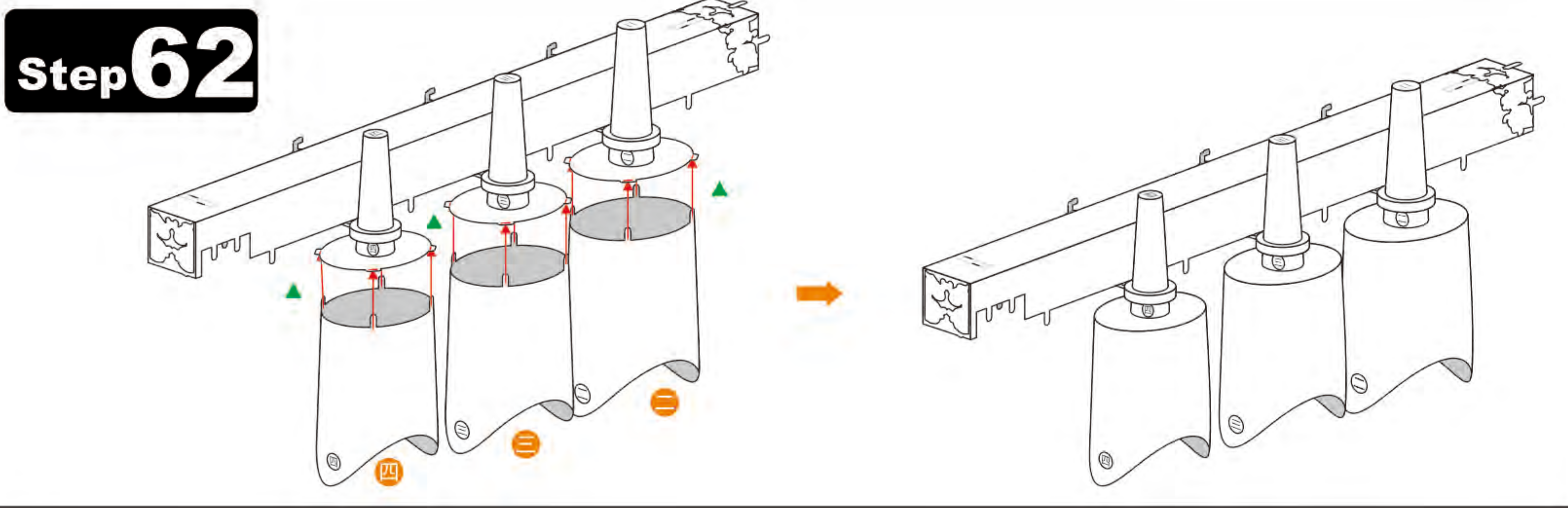

Step 63

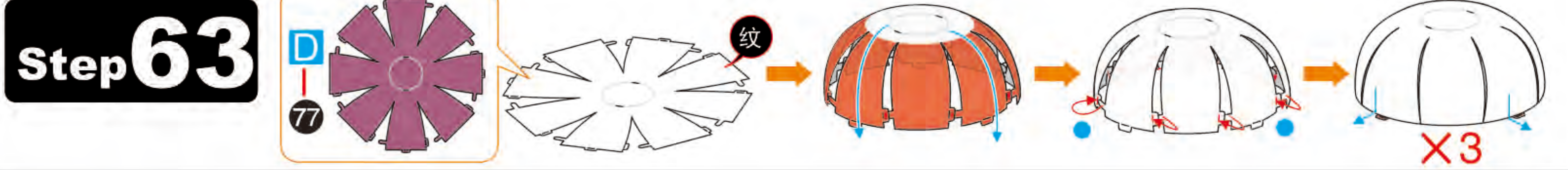

Step 64

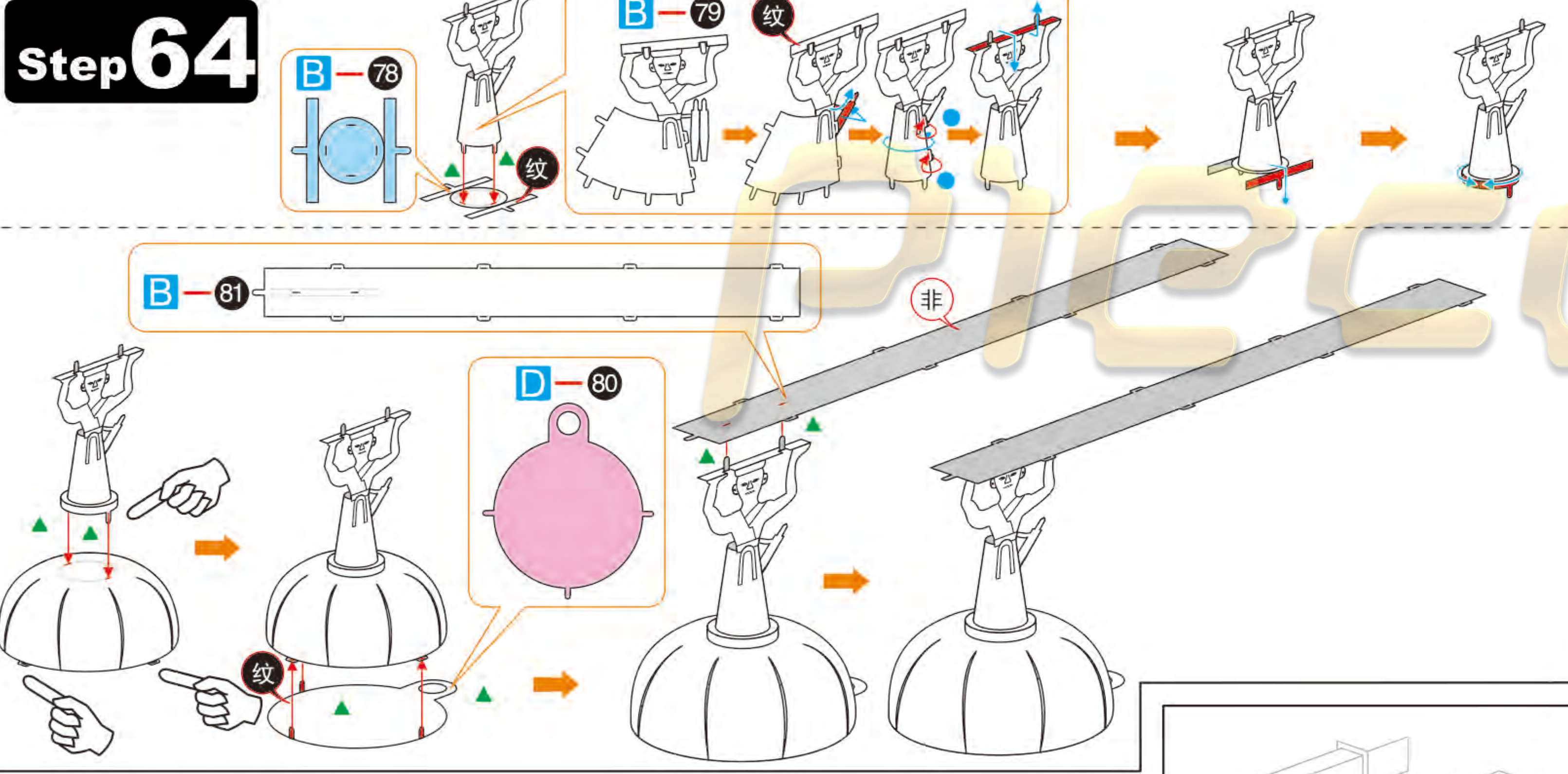

Step 65

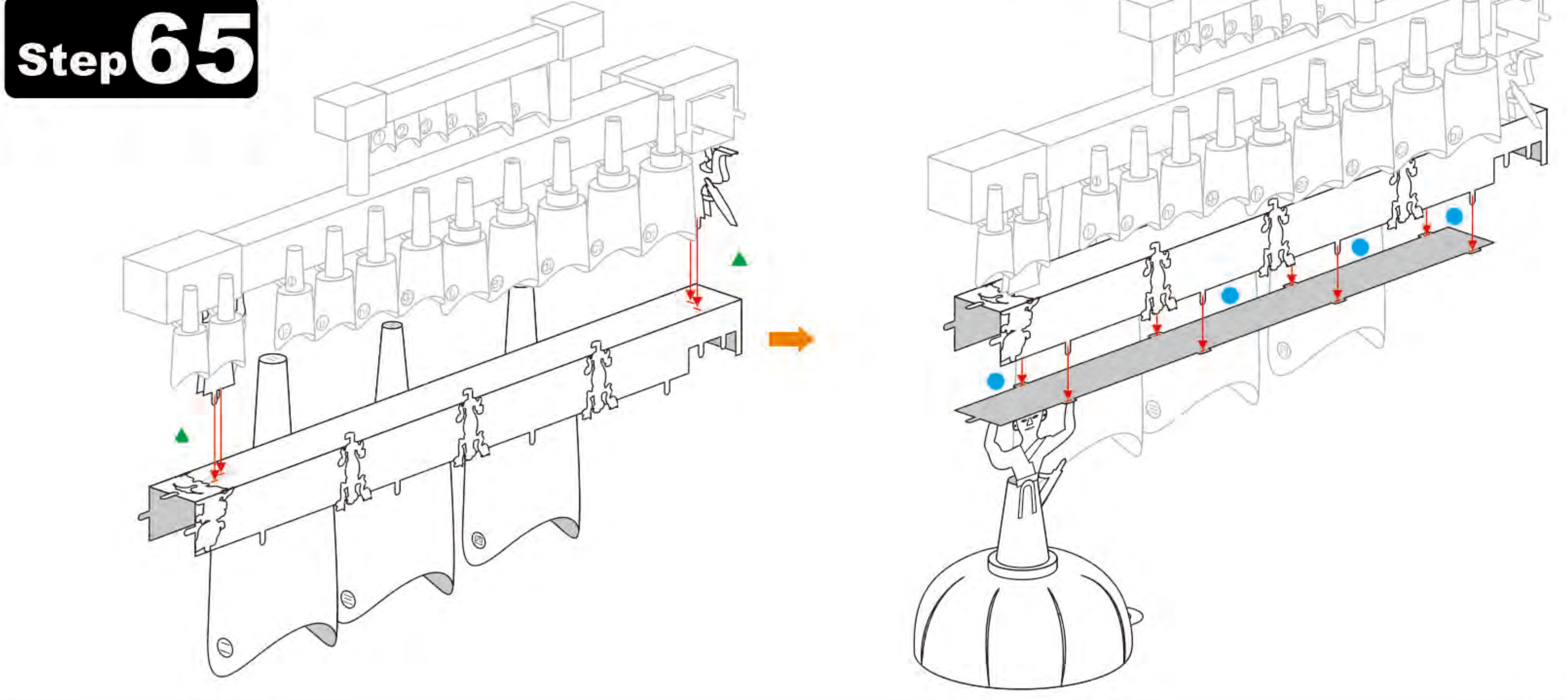

Step 66

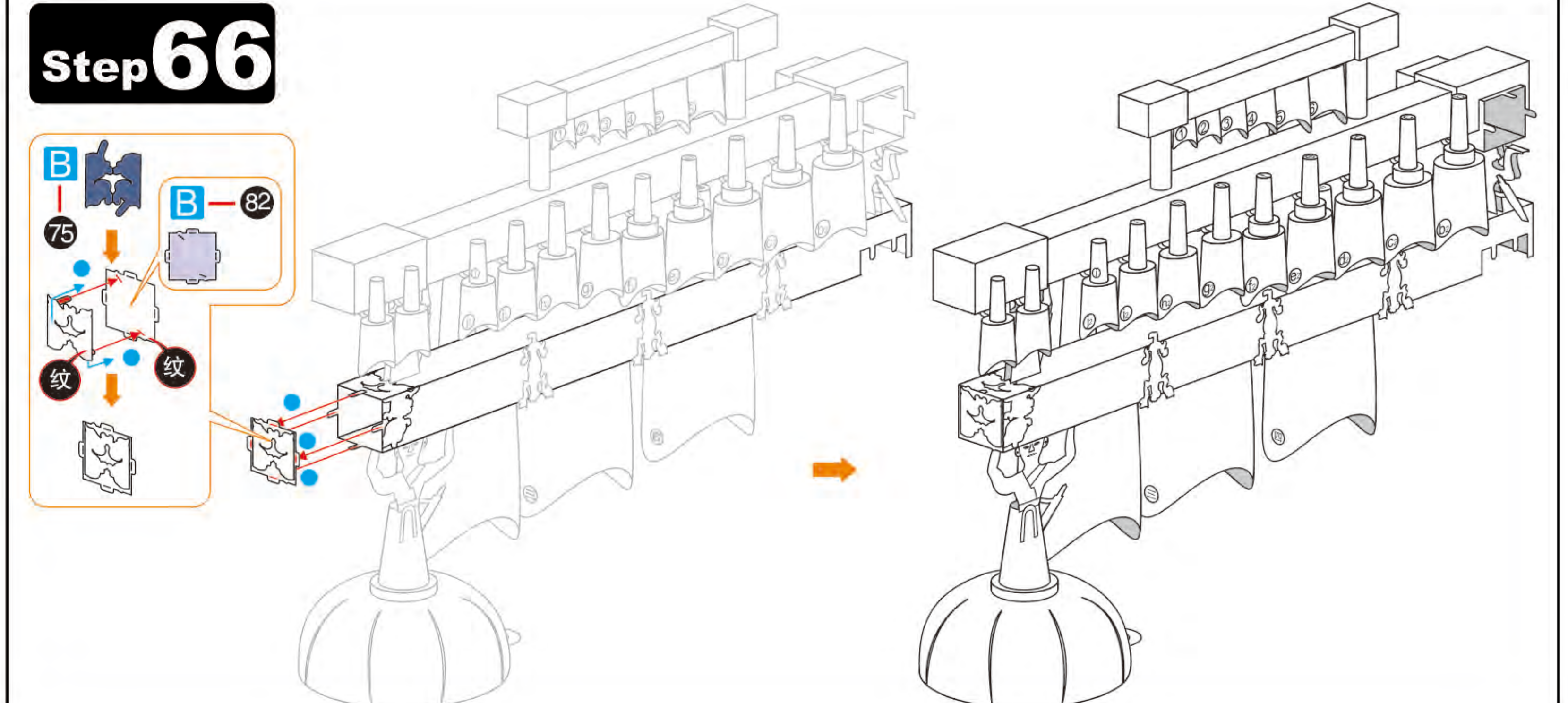

Step 67

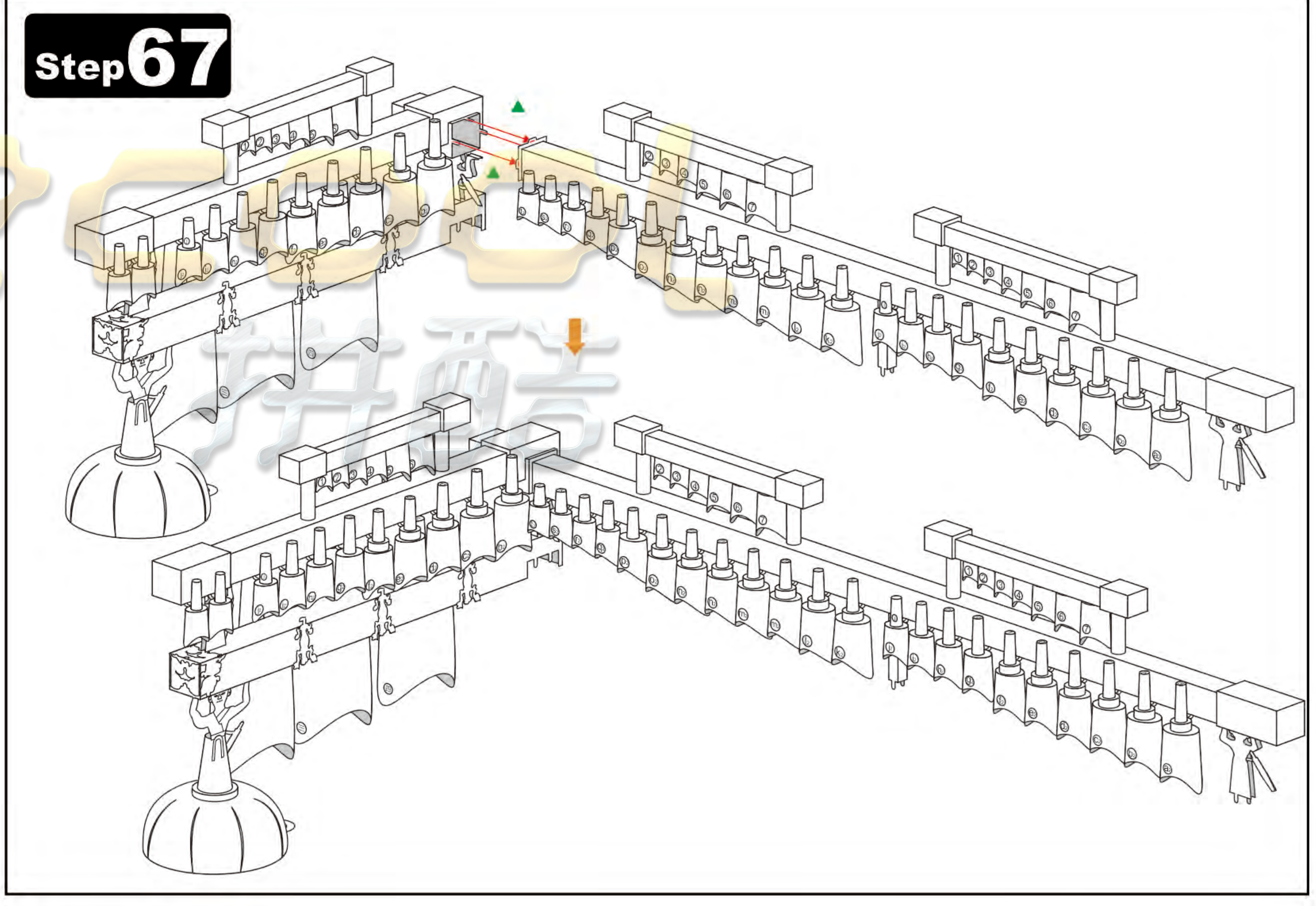

Step 68

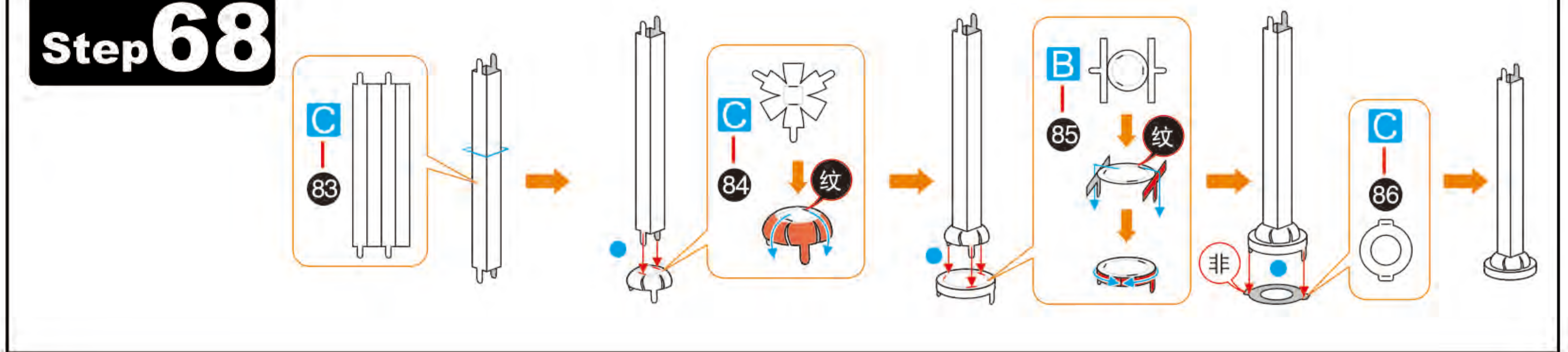

### Step 69

### Step 70

### Step 71

### Step 72

### Step 73

### Step 74

### Step 75

### Step 76

### Step 77

### Step 78

Piececool  
拼酷

[www.Piececool.com](http://www.Piececool.com)

© WIST PLASTIC & METAL TECHNOLOGY LIMITED. ALL RIGHTS RESERVED.