

MERRY GO AROUND 旋轉木馬 HP082

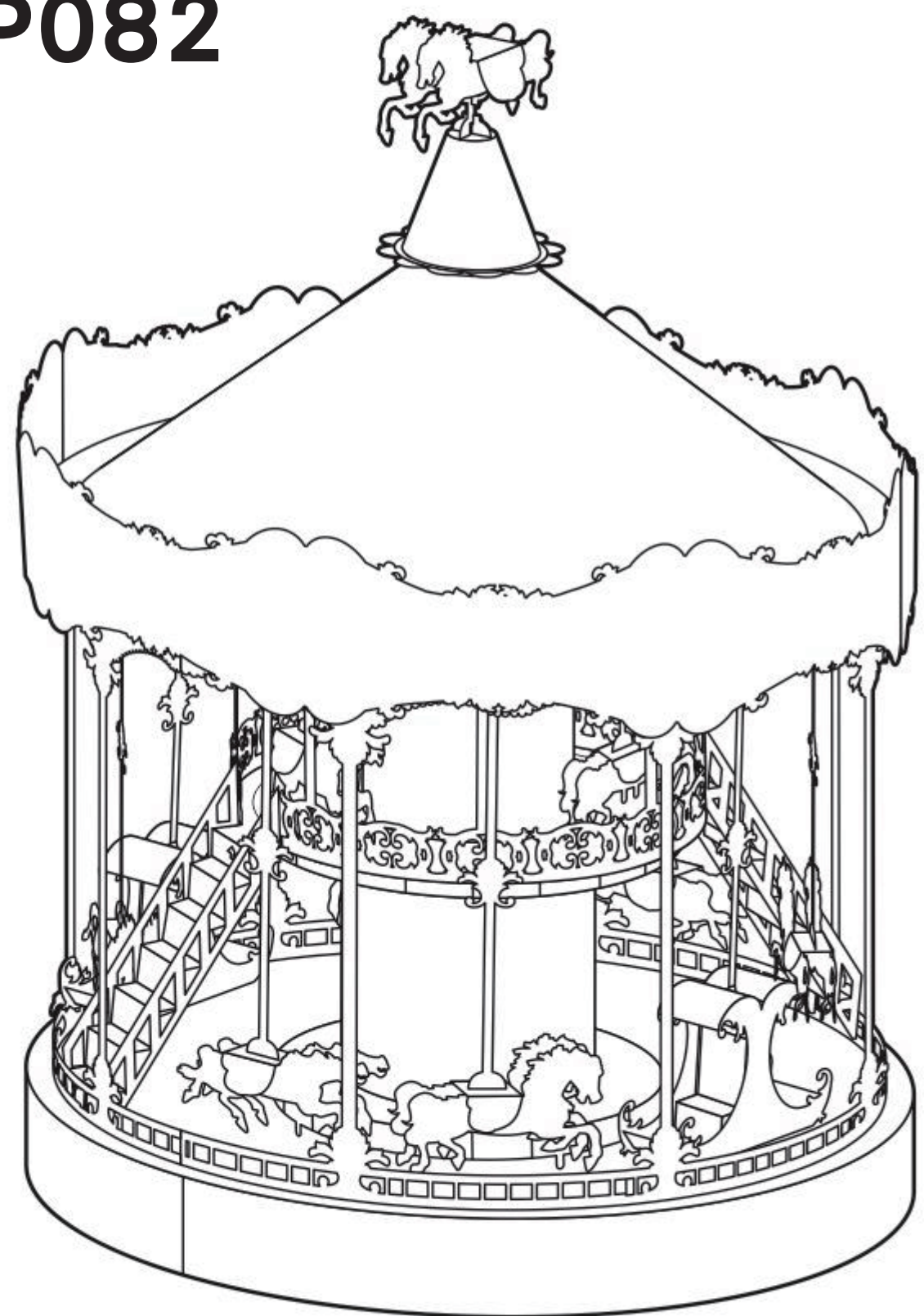

CP-ASSY-HP082#-A1-20190831

Installation Reminder / 拼前需知

- Insert the hole, bending tab with angle 90°
插入扣孔，平折90°
- ▲ Insert the hole, twisting tab with angle 90°
插入扣孔，旋轉90°

Insert tab / 扣點
Fold line / 折疊線
Insert hole / 扣孔

Ⓔ Engraved / Color side
顏色面 / 紋理面
Ⓗ Non-engraved / Silver side
非顏色面 / 非紋理面
! Attention Point
注意細節
! keep the parts symmetrical
注意片對稱

Metal Sheet Sketch Map / 金屬板板件示意圖

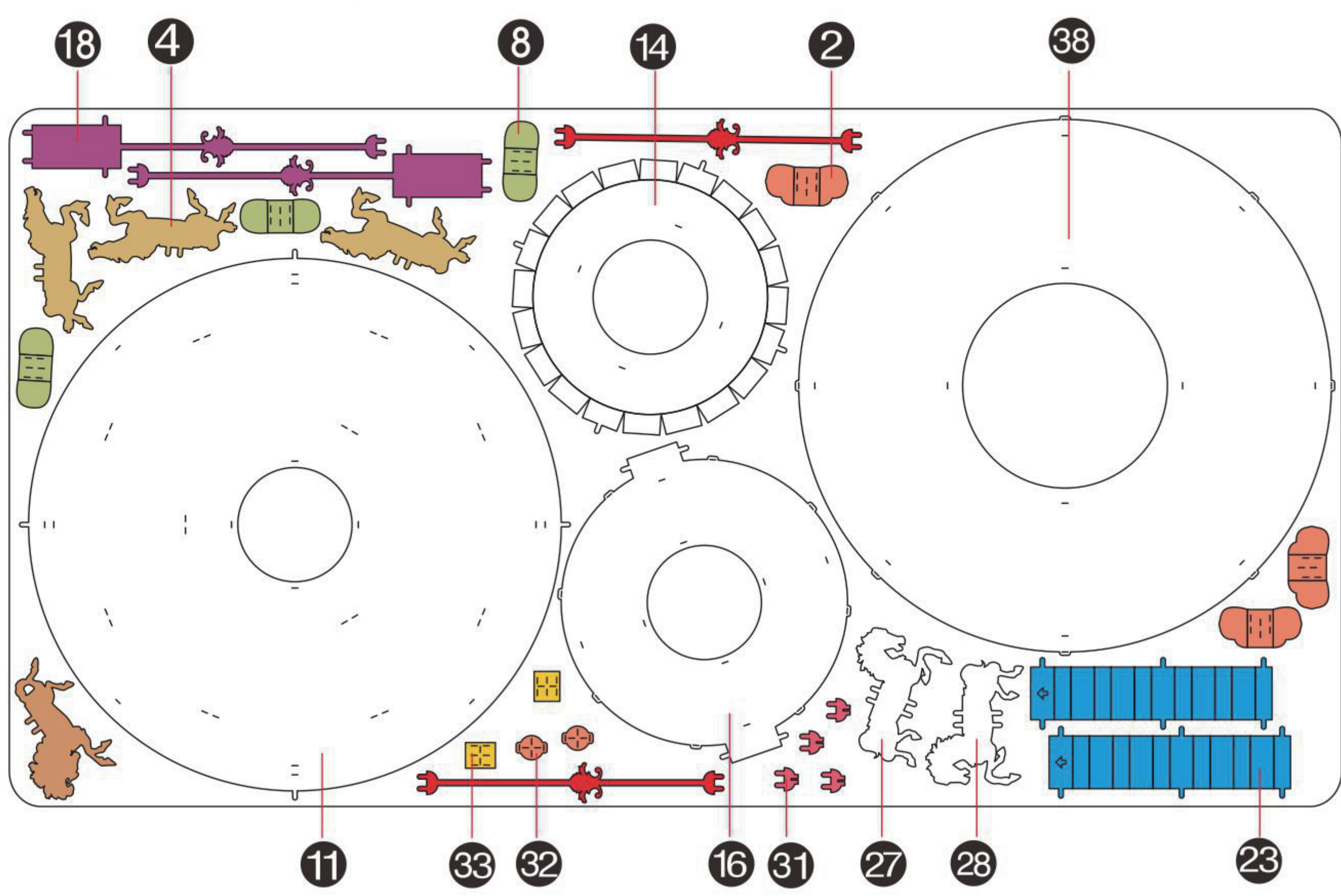

⚠ Please handle the metal trim carefully to prevent scratches.
組裝時請小心處理金屬零件，以防劃傷。

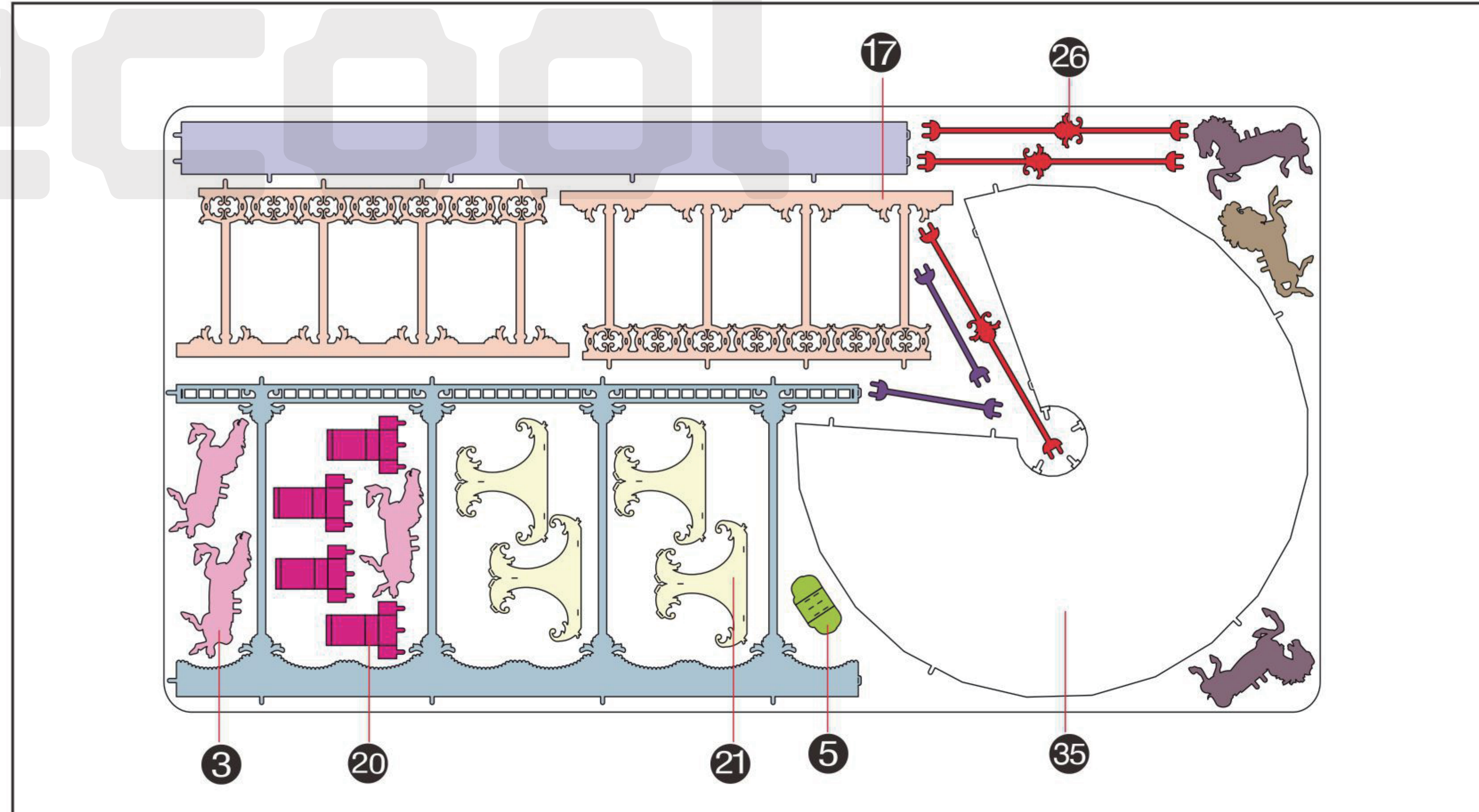
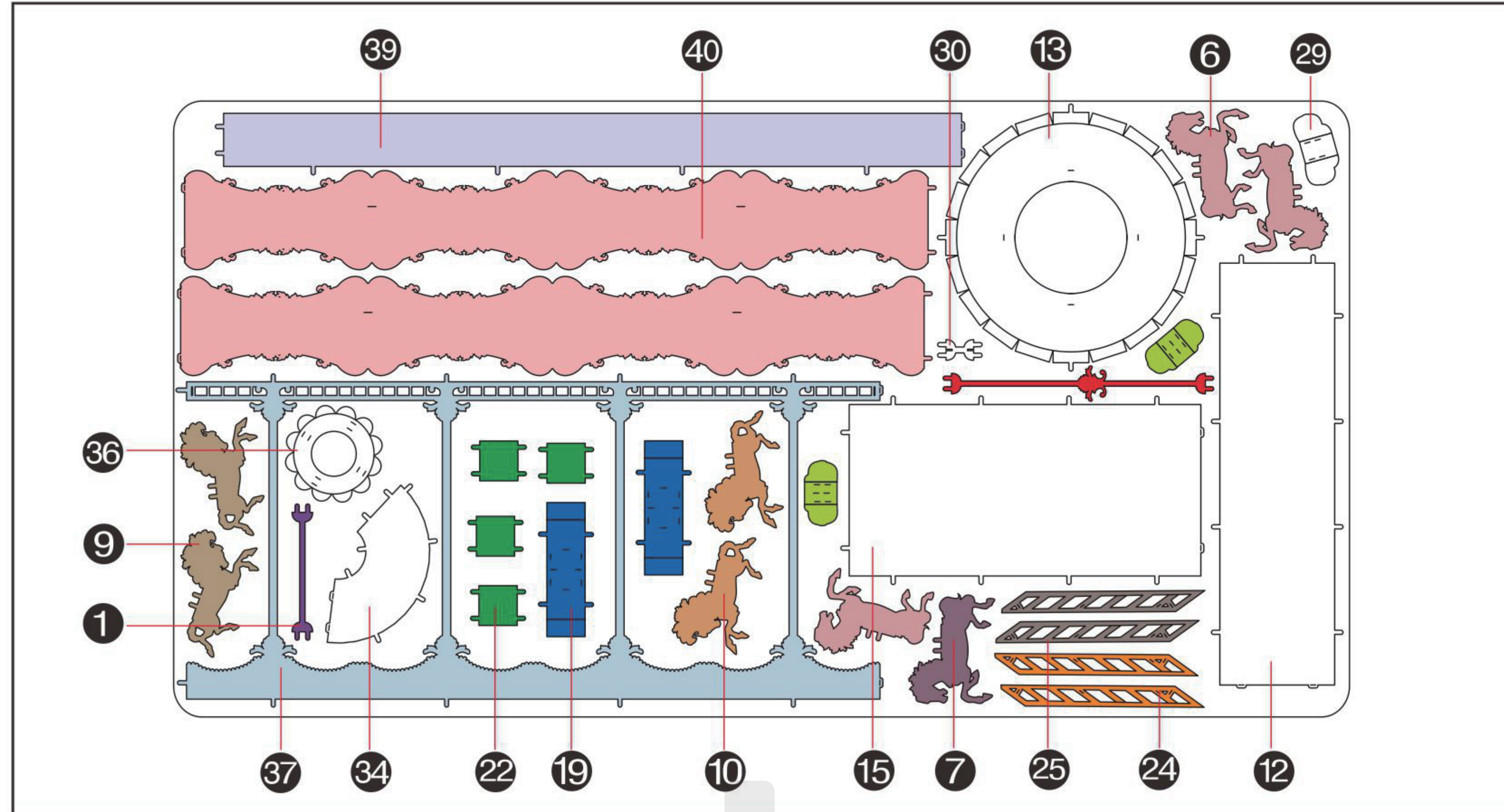

Assembly Guide / 拼裝步驟

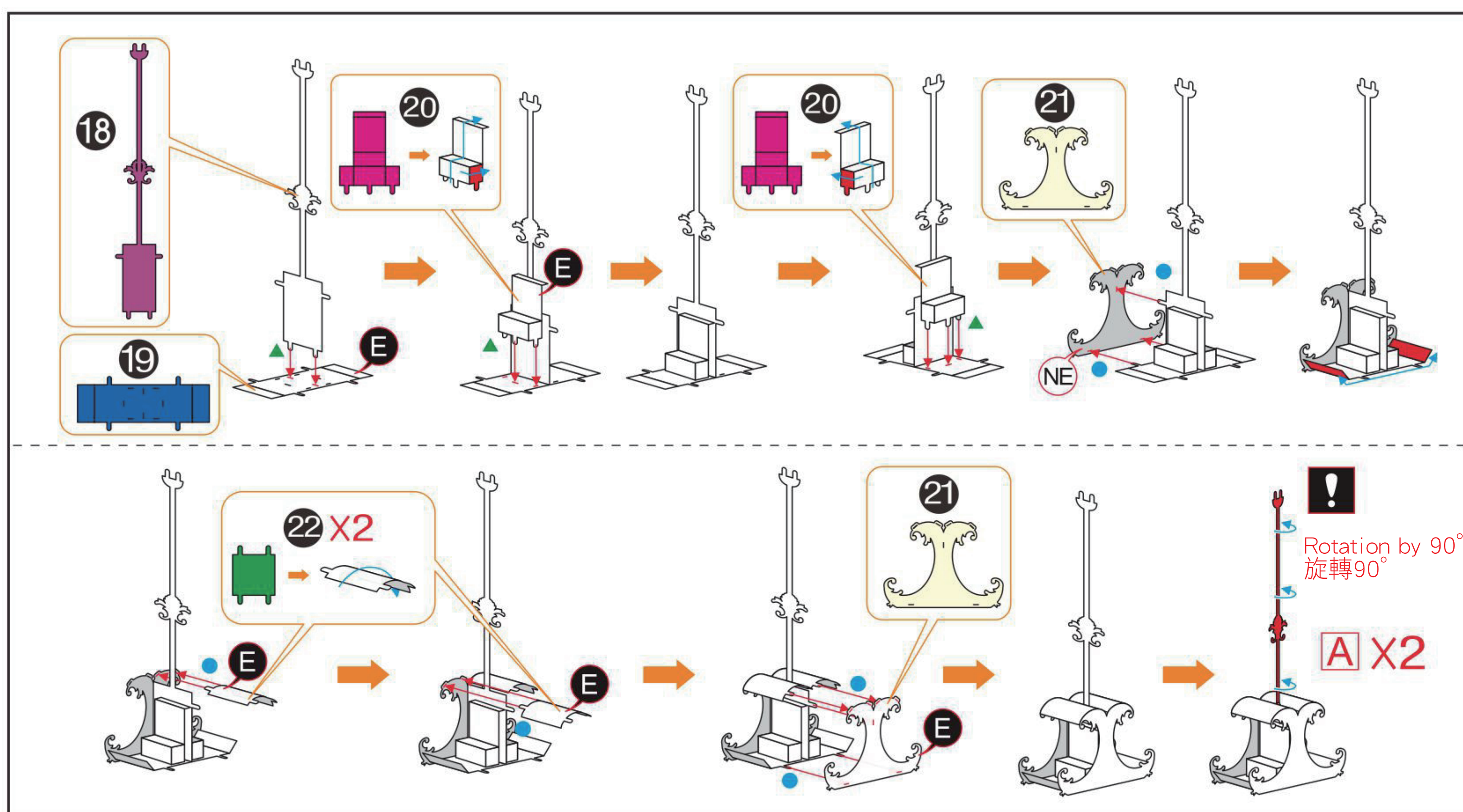
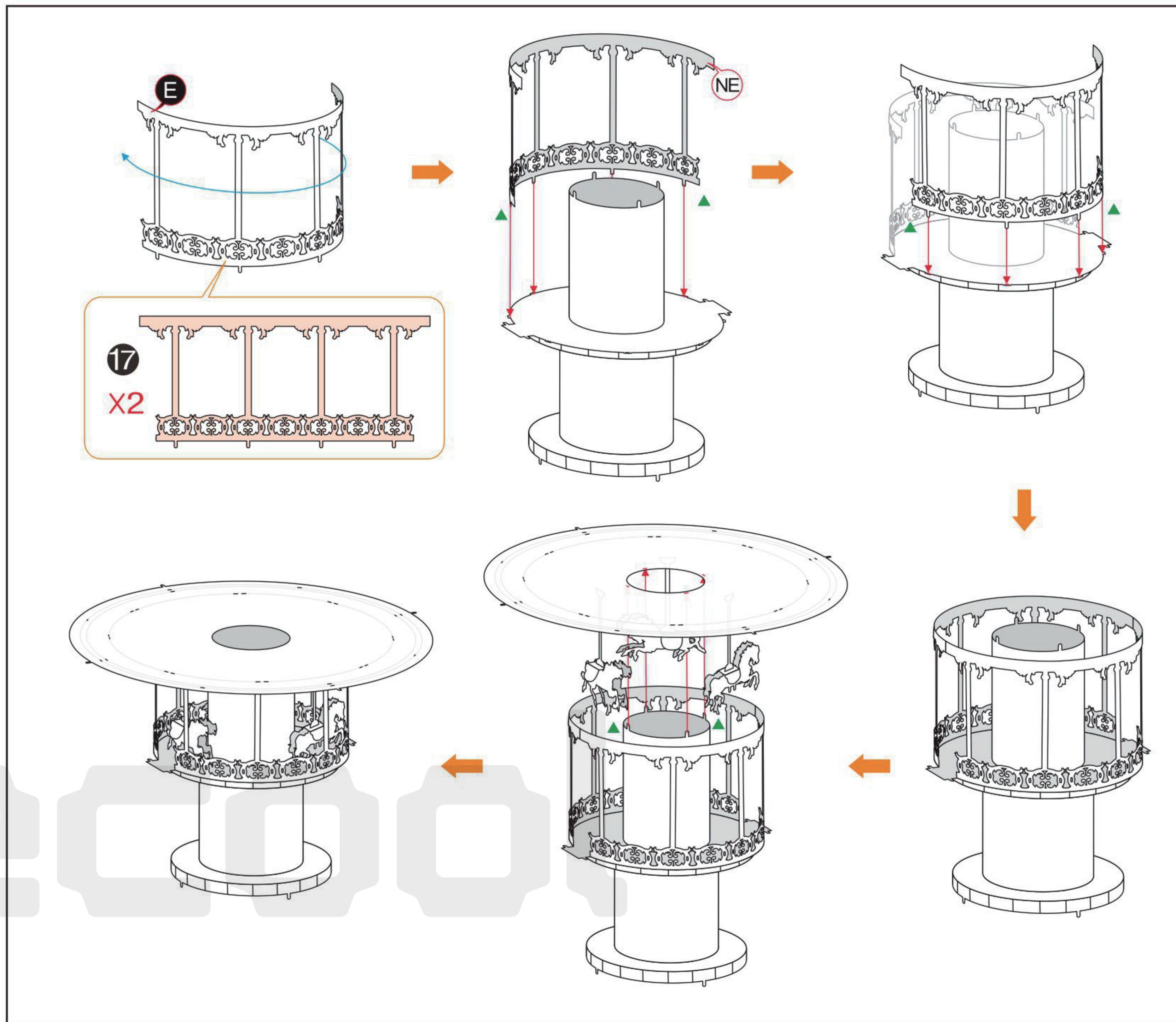
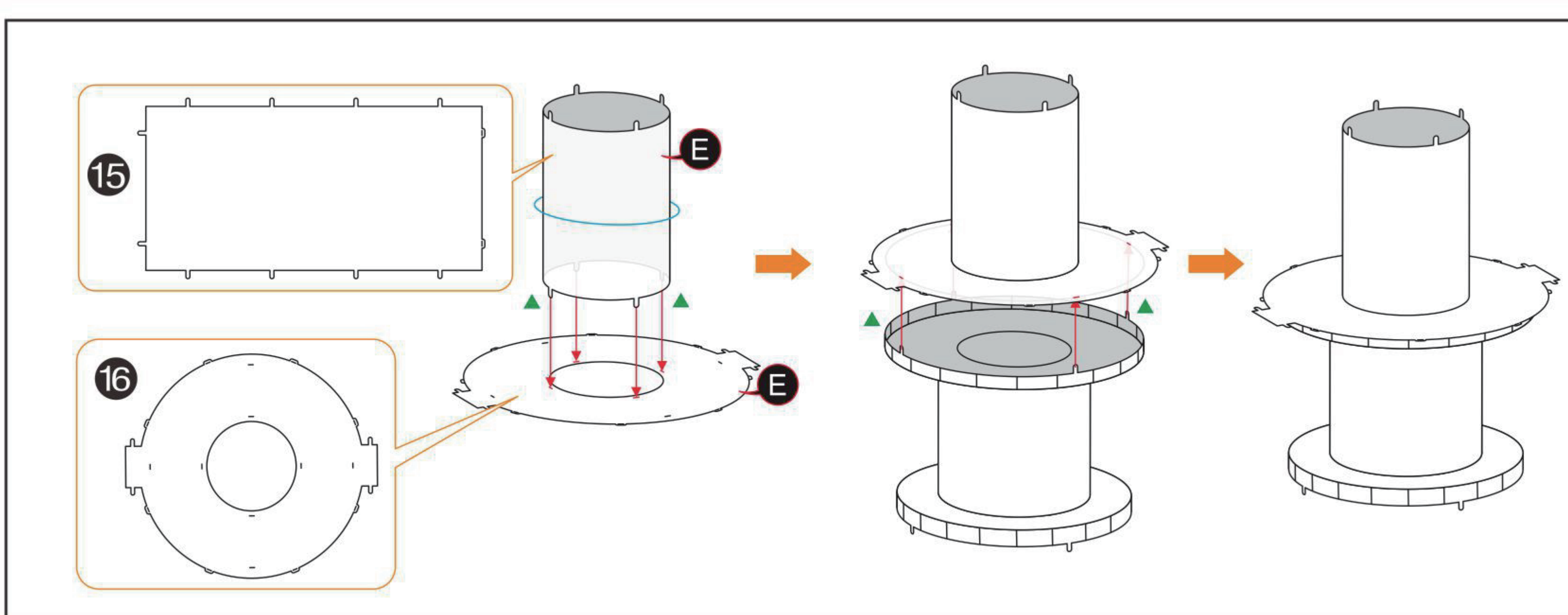
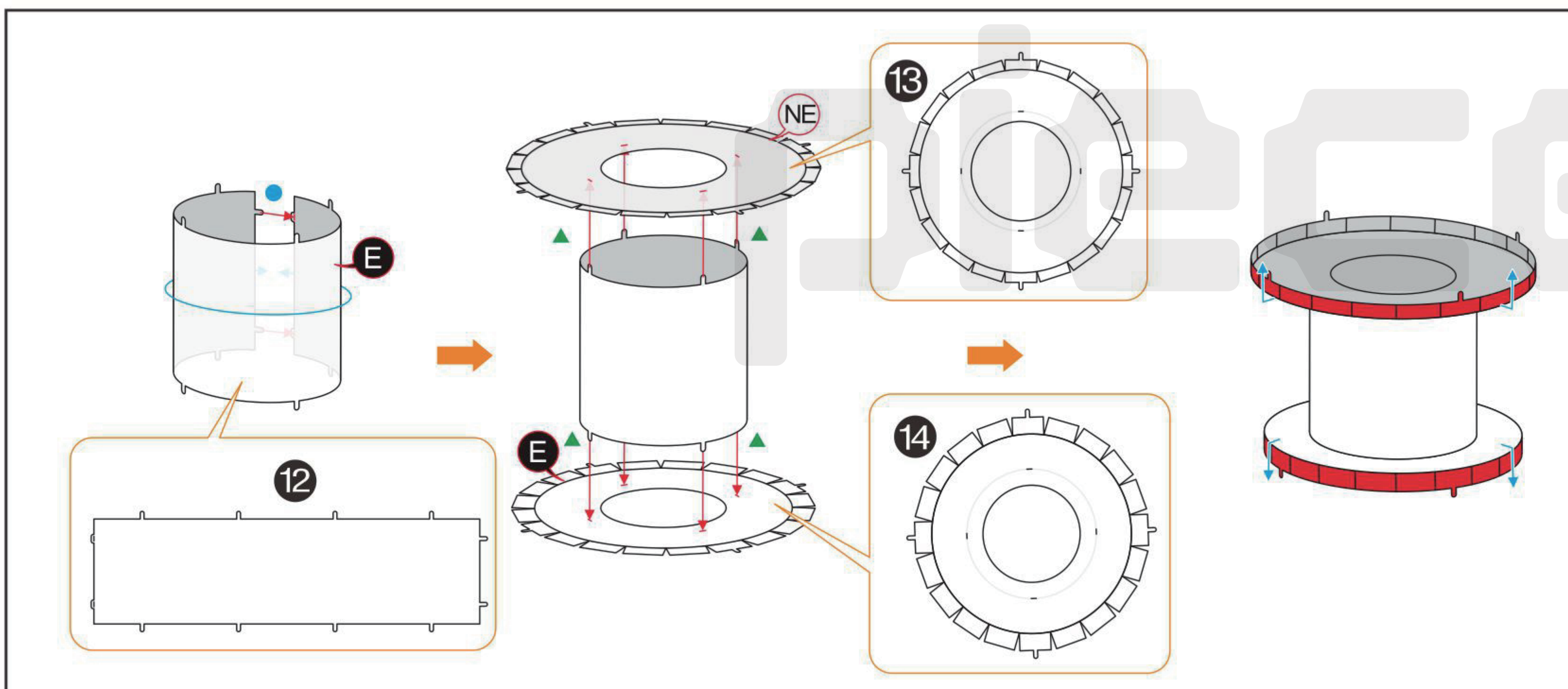
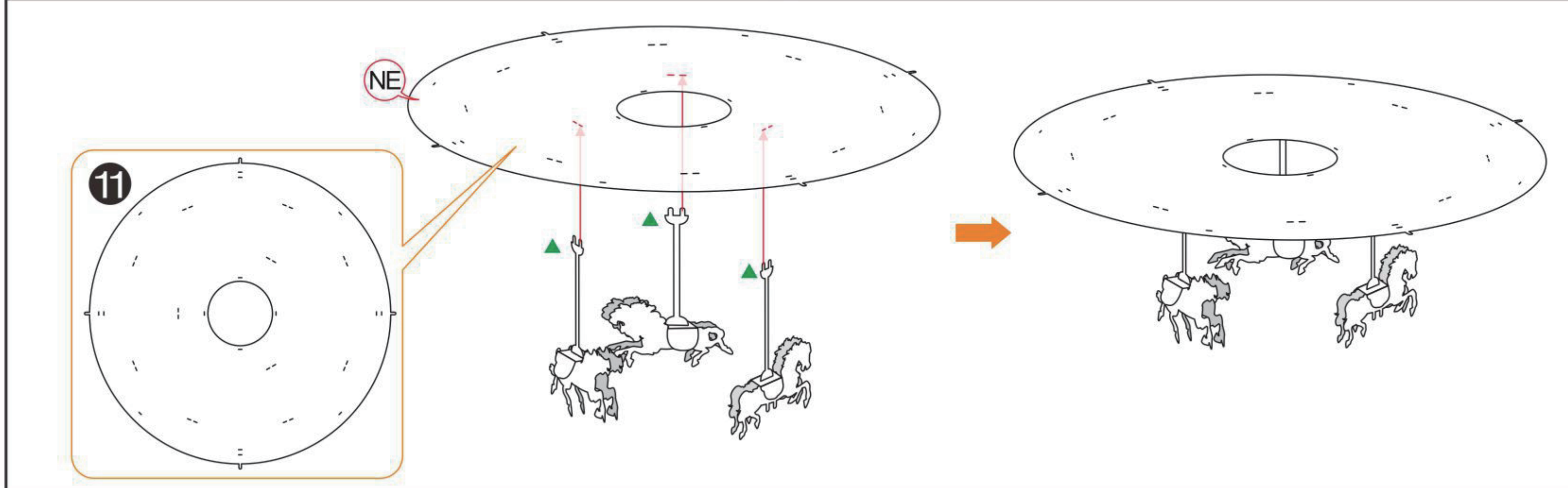
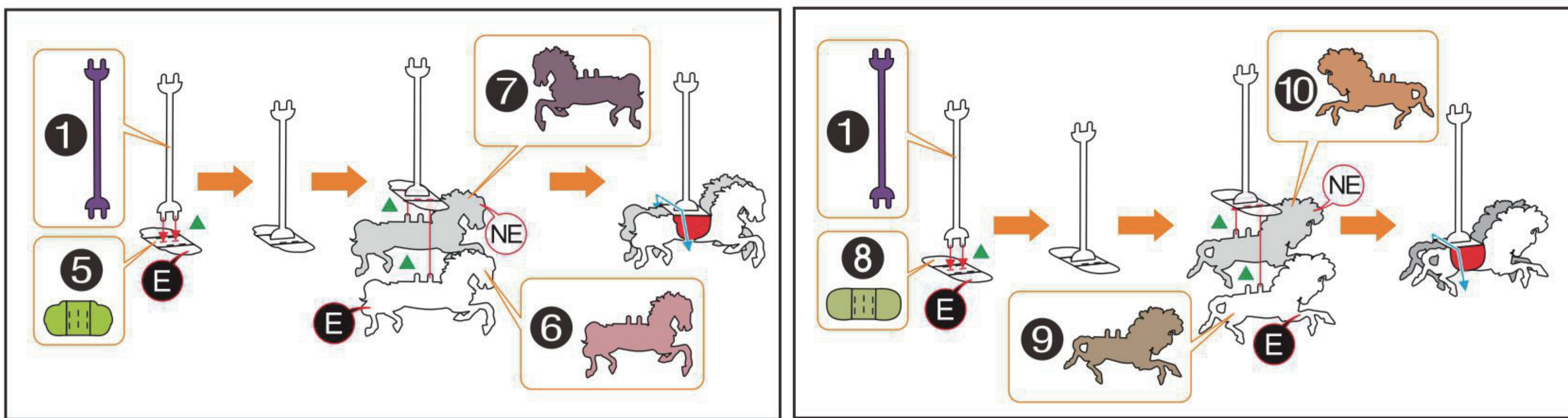
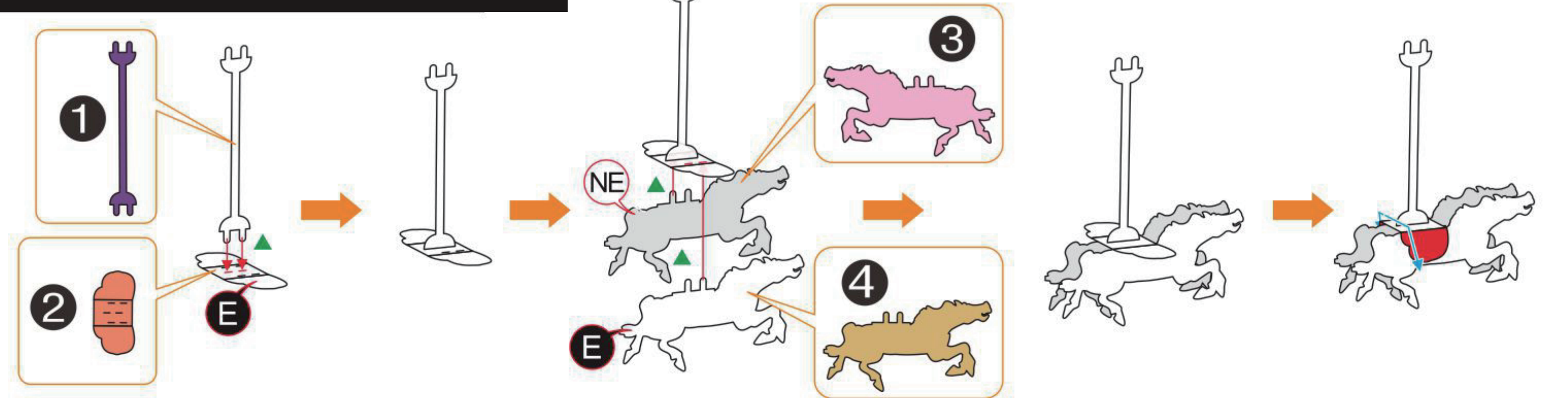

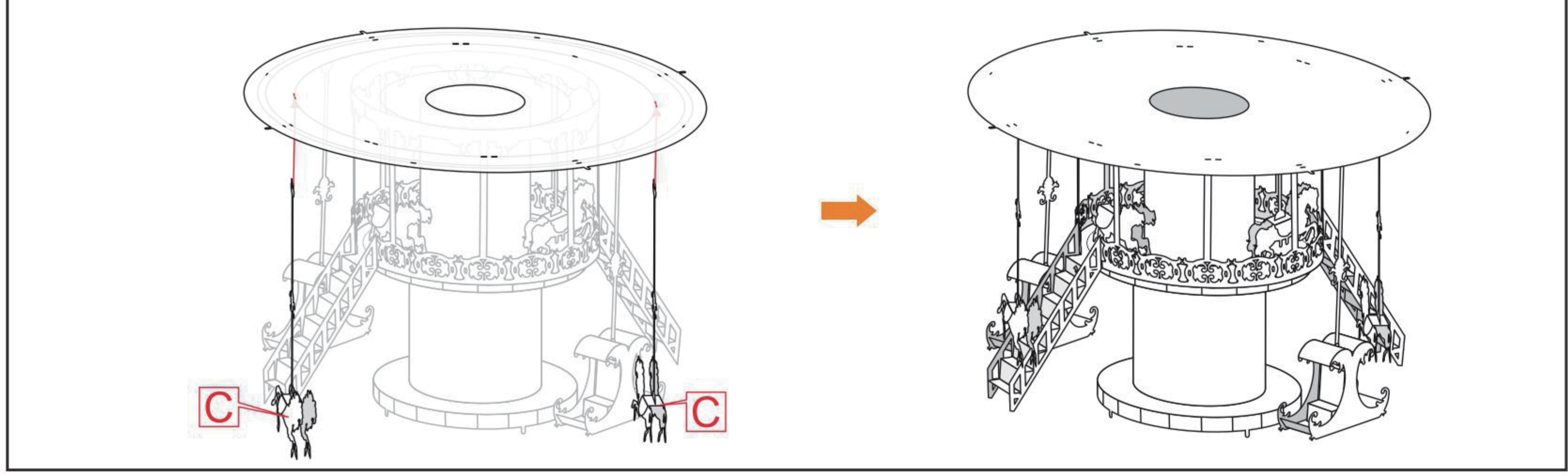
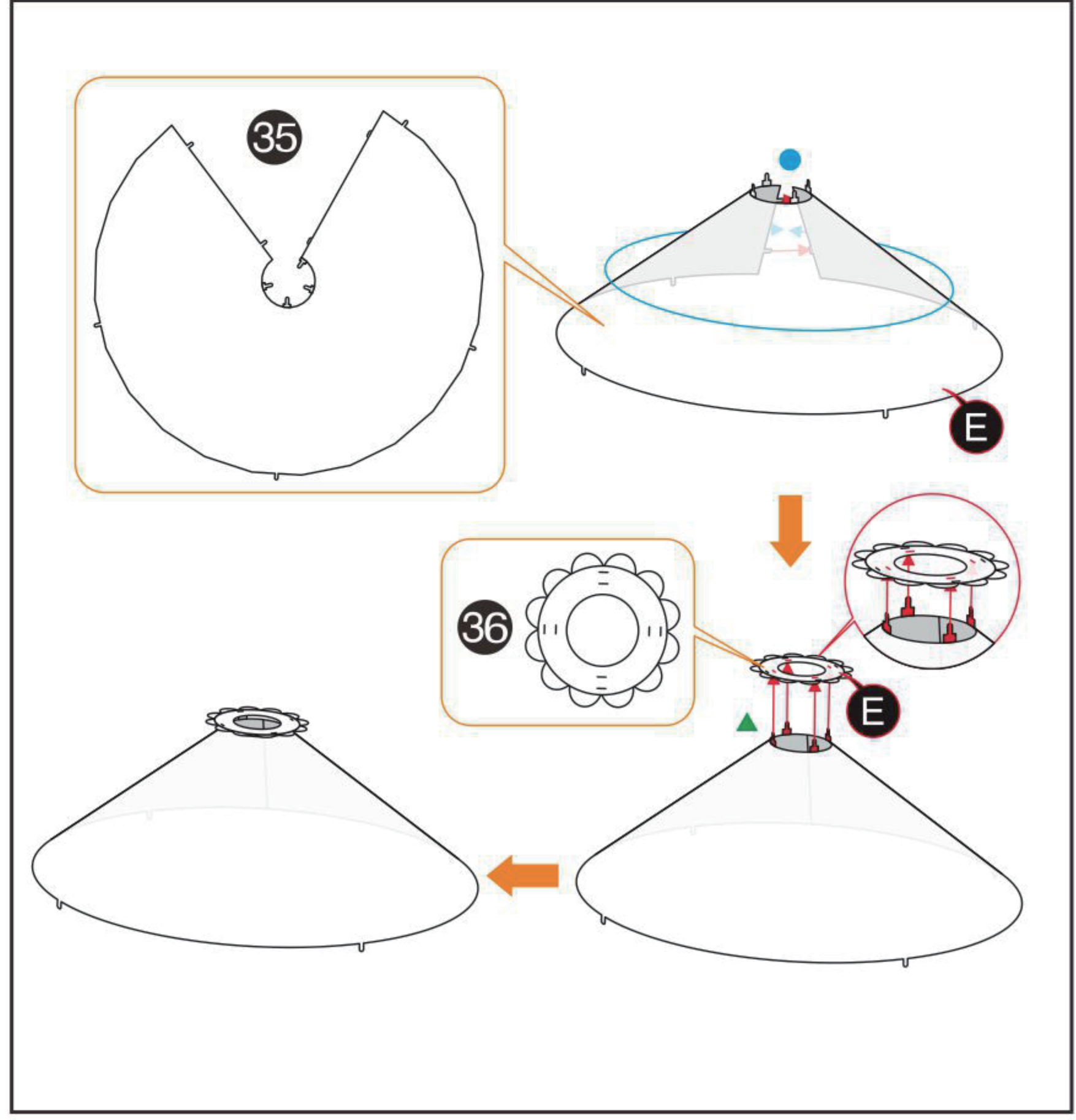
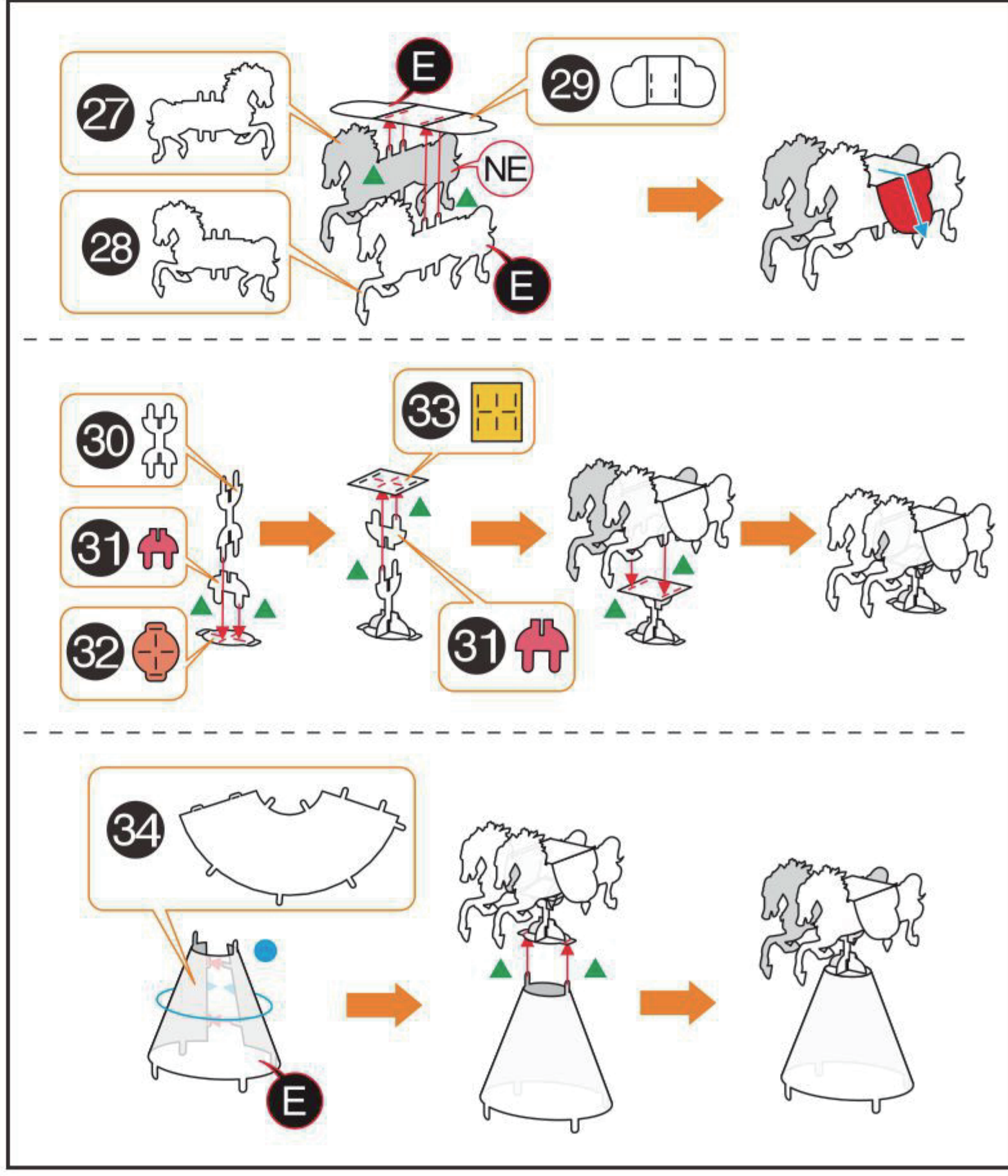
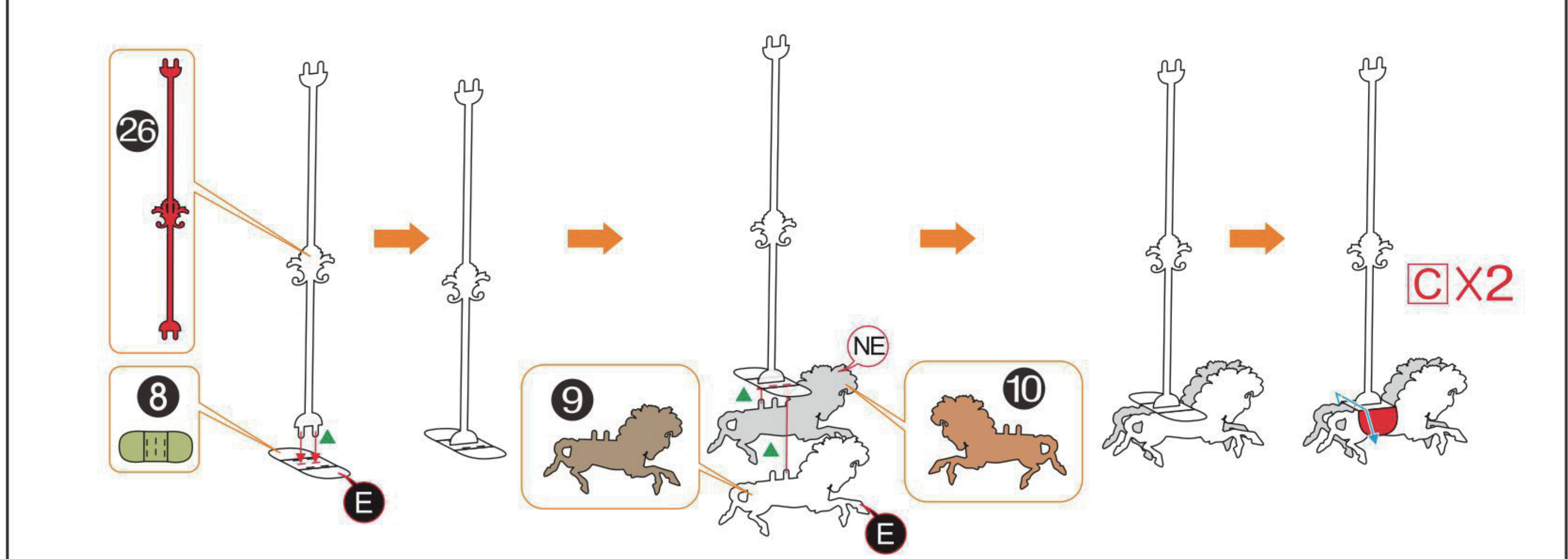
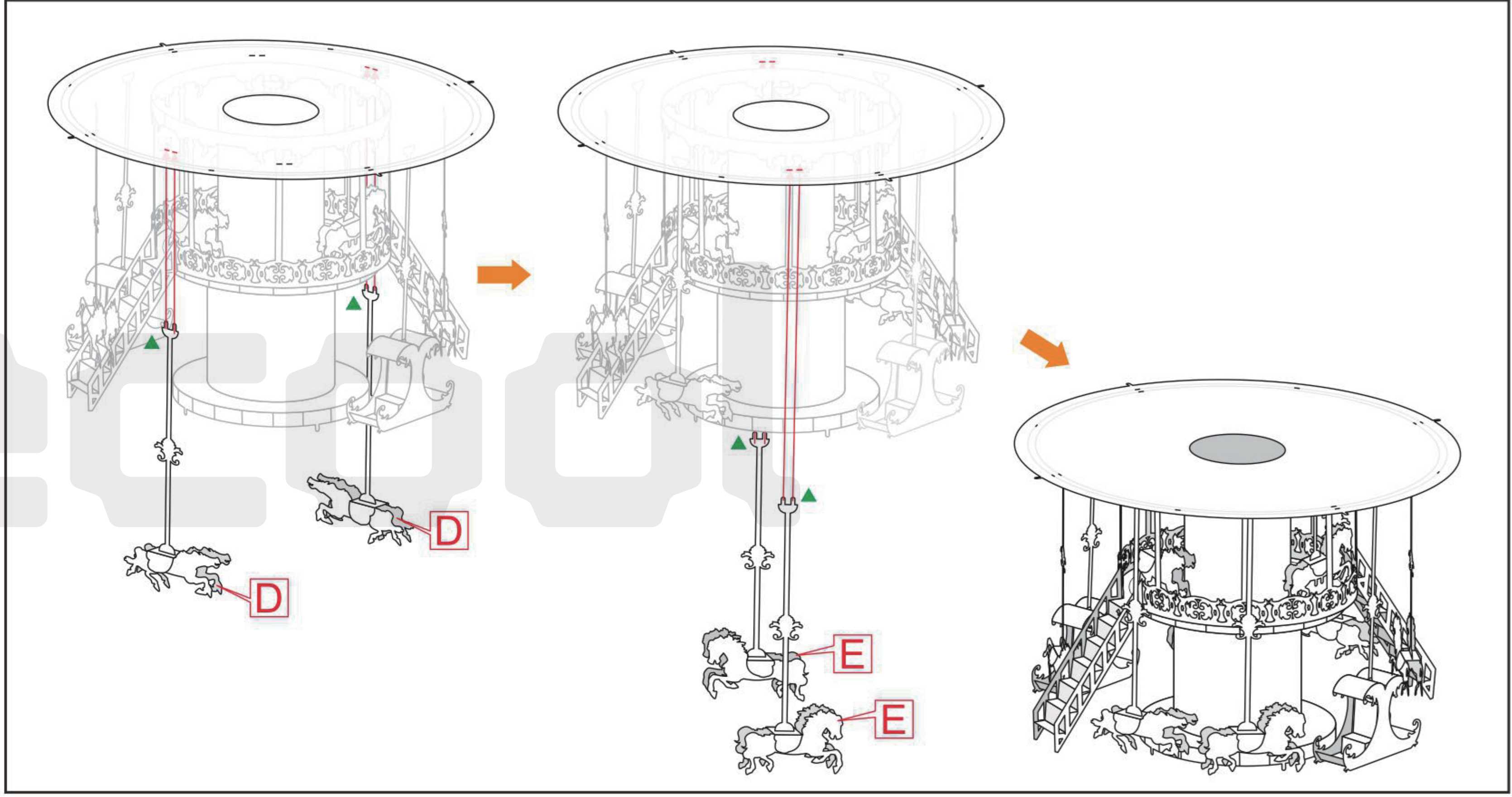
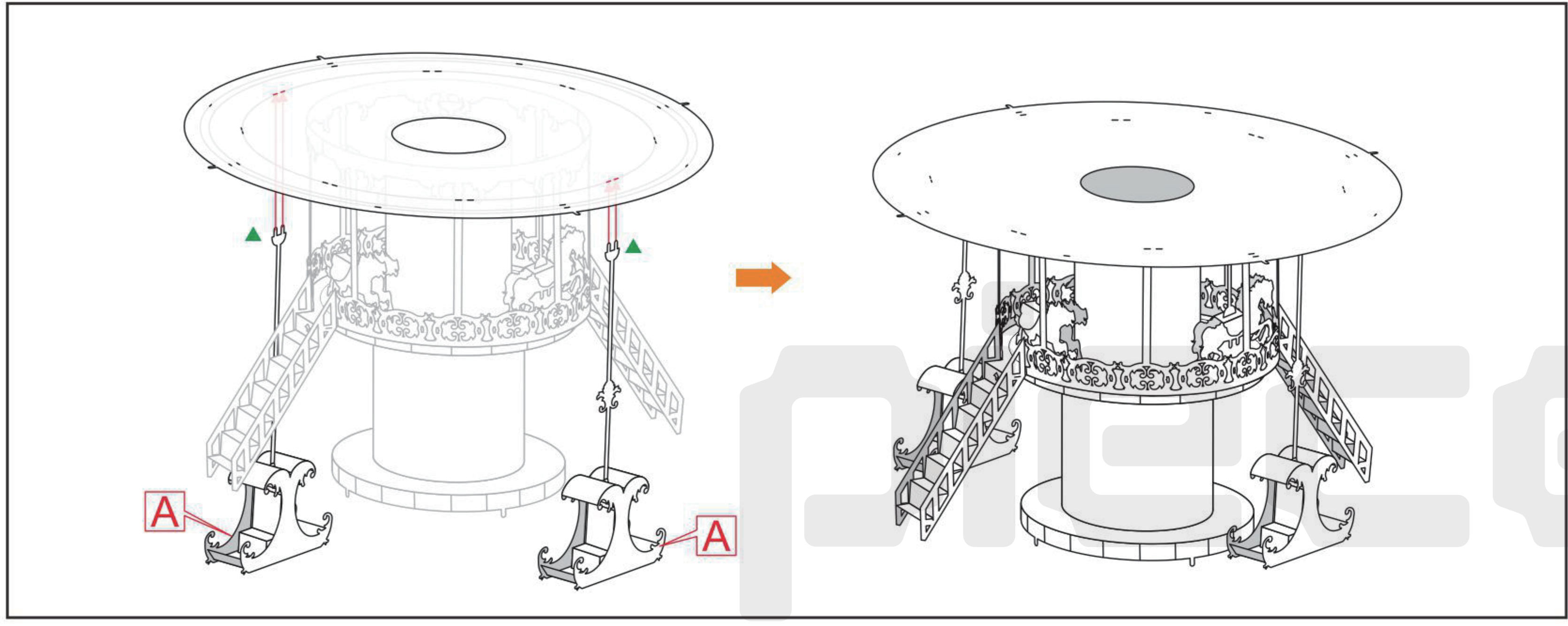
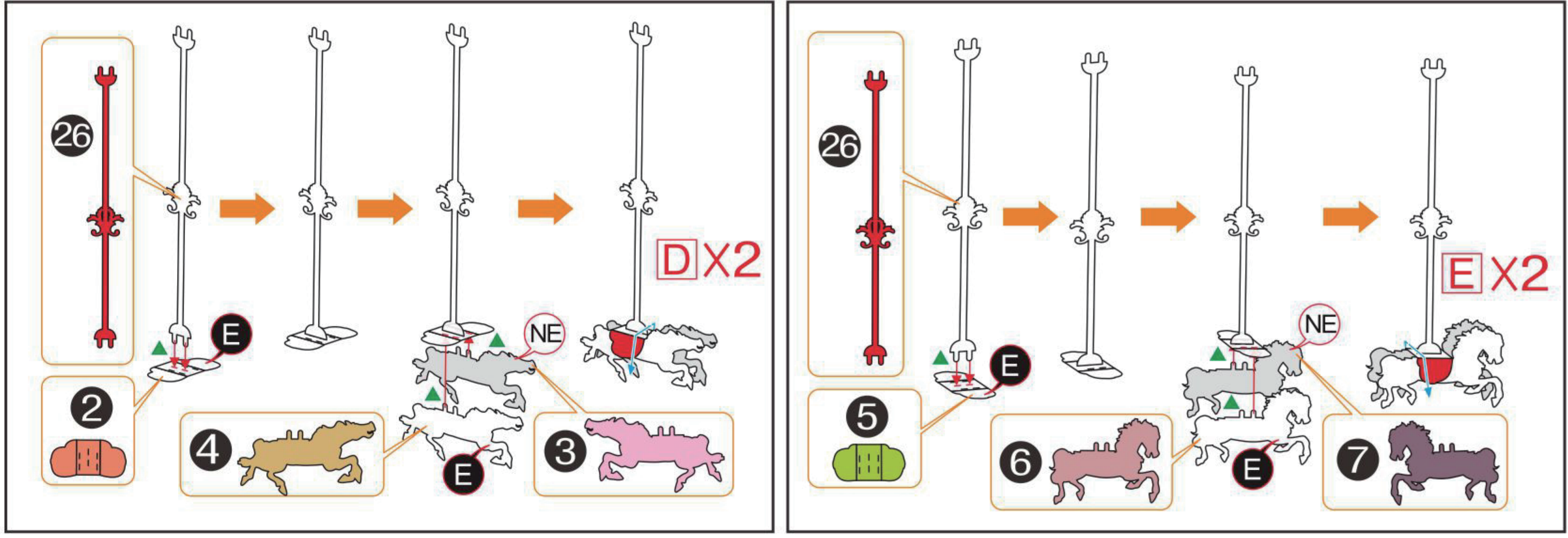
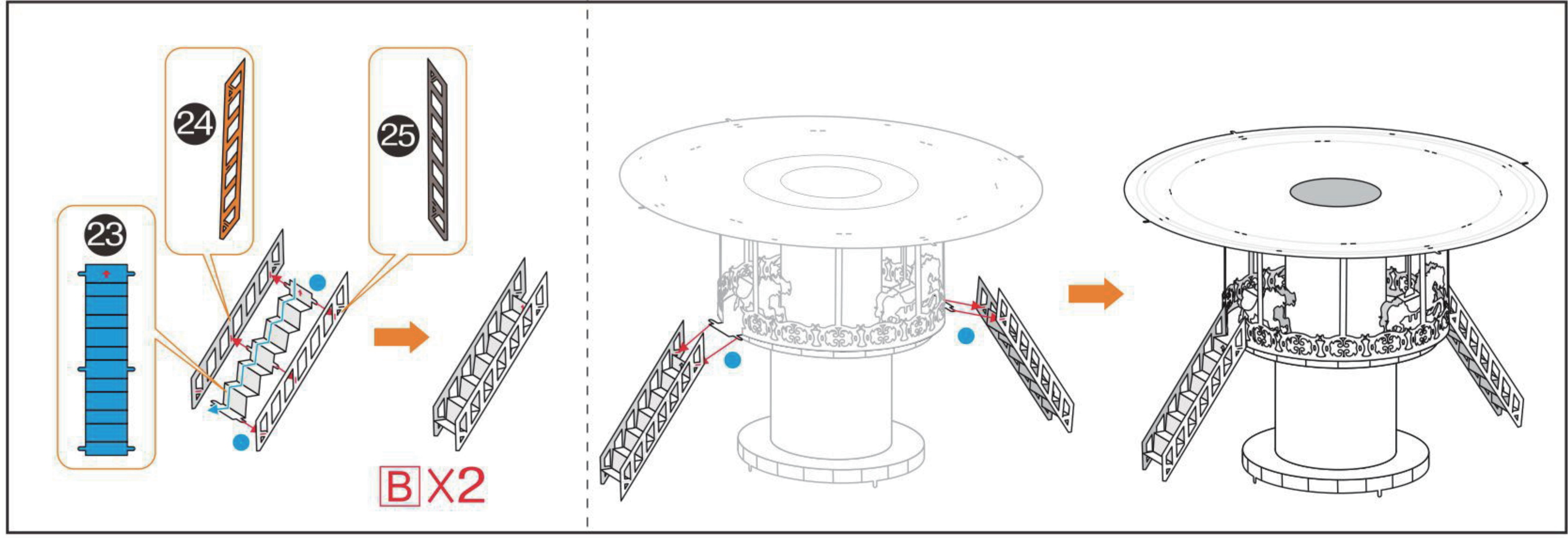

5
6

